

Name: _____ Date: _____ Event: _____ Track: _____

Track Conditions

Indoor Clay Carpet Tight Smooth Hard Packed Blue Groove Wet Bite: Low Med High Other: _____
 Outdoor Dirt Astro Open Rough Loose/Loamy Dry Dusty Tread: Pin Ghost Slicks

Front Suspension

Ride Height	_____	mm
Camber	_____	°
Toe	_____	°
Sway Bar	_____	mm
Notes:	_____ _____ _____	

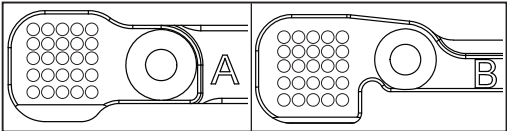
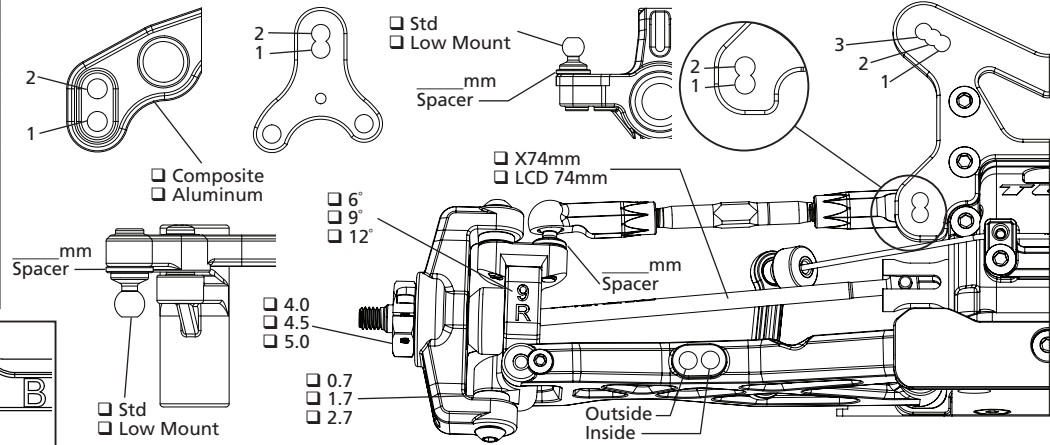

Rear Suspension

Ride Height	_____	mm
Camber	_____	°
Sway Bar	_____	mm
Notes:	_____ _____ _____	

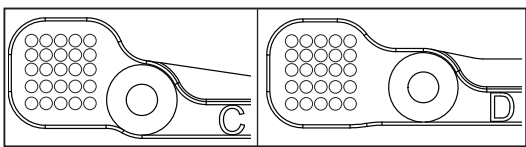
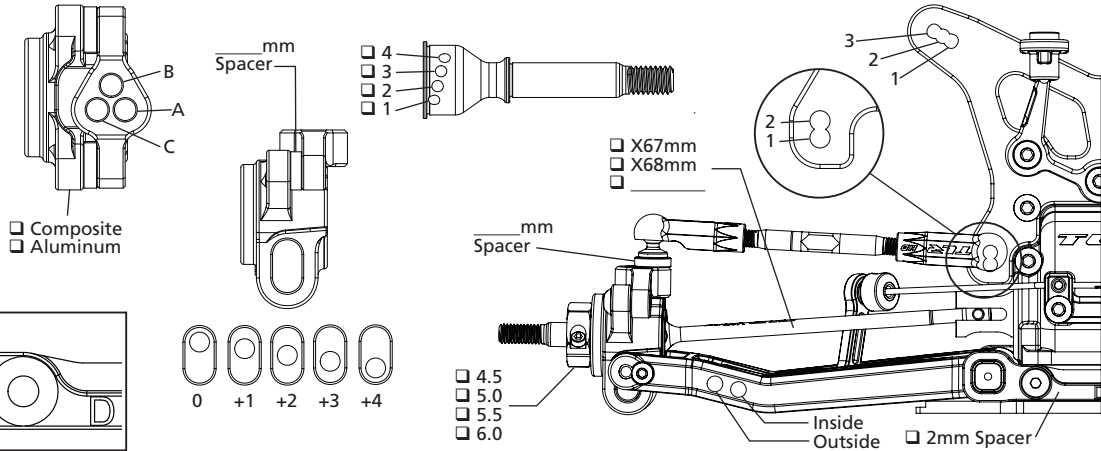

Chassis

Differentials	Front	Center	Rear
Fluid			
Int Gears	<input type="checkbox"/> Stl <input type="checkbox"/> Comp	<input type="checkbox"/> Stl <input type="checkbox"/> Comp	<input type="checkbox"/> Stl <input type="checkbox"/> Comp
Weight	_____ g	_____ g	_____ g
Ring/Pin	<input type="checkbox"/> Stl <input type="checkbox"/> Comp	<input type="checkbox"/> Stl <input type="checkbox"/> Comp	<input type="checkbox"/> Stl <input type="checkbox"/> Comp
Center Diff Cover	<input type="checkbox"/> Composite <input type="checkbox"/> Aluminum		
Slipper Pads	<input type="checkbox"/> Torque/Yellow <input type="checkbox"/> Drive/Orange		

Aerodynamics	
Body	
Fr Scoop	
Rr Wing	
Wicker	
Angle	
Notes	

Tires	Front	Rear
Brand		
Tread		
Compound		
Insert		
Sauce		
Wheel		
Notes		

Shocks

	Front	Rear
Shock Caps		
Oil		
Piston		<input type="checkbox"/> Thin
Limiter, Int	_____ mm	_____ mm
Shaft Dia	<input type="checkbox"/> 3.0mm <input type="checkbox"/> 3.5mm	<input type="checkbox"/> 3.0mm <input type="checkbox"/> 3.5mm
Limiter, Ext	_____ mm	_____ mm
Stroke	_____ mm	_____ mm
Eyelet	<input type="checkbox"/> Std <input type="checkbox"/> +2mm	<input type="checkbox"/> Std <input type="checkbox"/> +2mm
Spring		
Spring Cup	<input type="checkbox"/> Low <input type="checkbox"/> Mid <input type="checkbox"/> High	<input type="checkbox"/> Low <input type="checkbox"/> Mid <input type="checkbox"/> High

Electronics

Radio		ESC	
Servo		Thro Prof	
Battery		Timing Adv	
Battery Wt	_____ g	Initial Brake	
Motor		Drag Brake	
Gearing	/	Thr/Bra EPA	/

