



FUZE™ 60A Sport Brushless ESC

Instruction Manual

(DYN52406)

ENGLISH

NOTICE
All instructions, warranties and other collateral documents are subject to change at the sole discretion of Horizon Hobby, LLC. For up-to-date product literature, visit horizonhobby.com or towerhobbies.com and click on the support or resources tab for this product.

MEANING OF SPECIAL LANGUAGE

The following terms are used throughout the product literature to indicate various levels of potential harm when operating this product:
WARNING: Procedures, which if not properly followed, create the probability of property damage, collateral damage, and serious injury OR create a high probability of superficial injury.
CAUTION: Procedures, which if not properly followed, create the probability of physical property damage AND a possibility of serious injury.
NOTICE: Procedures, which if not properly followed, create a possibility of physical property damage AND a little or no possibility of injury.

WARNING: Read the ENTIRE instruction manual to become familiar with the features of the product before operating. Failure to operate the product correctly can result in damage to the product, personal property and cause serious injury.

This is a sophisticated hobby product. It must be operated with caution and common sense and requires some basic mechanical ability. Failure to operate this Product in a safe and responsible manner could result in injury or damage to the product or other property. This product is not intended for use by children without direct adult supervision. Do not attempt disassembly, use with incompatible components or augment product in any way without the approval of Horizon Hobby, LLC. This manual contains instructions for safety, operation and maintenance. It is essential to read and follow all the instructions and warnings in the manual, prior to assembly, setup or use, in order to operate correctly and avoid damage or serious injury.

Age Recommendation: Not for children under 14 years. This is not a toy.

SPECIFICATIONS

Type	Sensorless
Constant/Peak	60A/90A
Resistance	1.7mΩ
Function	Proportional forward, proportional reverse with braking delay
Input Voltage	2-3S LiPo, 6-8 Cell NiMH
BEC Output	6V/2A
Overload Protection	Thermal
Dimensions (LxWxH)	40mm x 32mm x 19mm
Weight	51g

QUICK START GUIDE

The quick start setup guide will get you running quickly using the ESC's default settings.

1. Mount the ESC and motor in the car.
2. Connect the ESC to the motor.
3. Connect the ESC receiver lead to CH2 on your receiver.
4. Ensure the ESC switch is OFF.
5. Connect a fully charged battery.
6. Calibrate ESC to the transmitter.
7. Set battery chemistry.

MOUNTING THE SPEED CONTROL

Mount the ESC in the location specified by your vehicle's instruction manual. Use double-sided foam tape to secure the speed control in position.

Ensure all wiring connections can be reached prior to mounting.
Use double-sided foam tape to secure the switch to a convenient location in the vehicle.

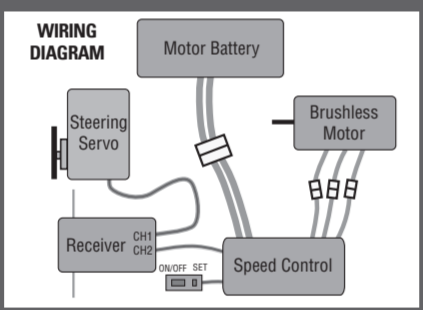

MOTOR TO ESC CONNECTION

1. Connect the blue motor lead to the blue ESC lead.
2. Connect the yellow motor lead to the yellow ESC lead.
3. Connect the orange motor lead to the orange ESC lead.

If the motor turns in the wrong direction, reverse the connection of any 2 motor wires.

NOTICE: Always disconnect the battery from the ESC when you have finished operating your vehicle. The ESC's switch only controls power to the receiver and servos. The ESC will continue to draw current when connected to the battery, resulting in possible damage to the battery through over discharge.

ESC CALIBRATION PROCEDURE

Ensure proper ESC function by calibrating the ESC to your transmitter inputs. The motor should be left connected during calibration, it will not run during calibration for safety.

1. Power OFF the ESC.
2. Ensure your transmitter is powered ON, the throttle is not reversed, the throttle trim is neutral and the throttle travel range is at 100%. Disable any special functions such as ABS, etc.
3. Press the SET button while powering ON the ESC. Release the button as soon as the red LED starts to flash and the motor emits a beep.
4. Calibrate the throttle points by pressing the SET button once after each step.
 - Set Neutral: leave the throttle at rest, untouched and press the SET button (1 green flash; 1 motor)
 - Set Full Throttle: pull the throttle fully back, then press the SET button (2 green flashes; 2 motor beeps)
 - Set Full Brake/Reverse: push the throttle fully forward, then press the SET button (3 green flashes; 3 motor beeps)

NOTICE: The motor will NOT run during the calibration procedure.

5. Power off the ESC. The ESC is calibrated and ready to run.

ESC FUNCTIONS AND MODES

The ESC includes programming options so you can adjust the way your vehicle performs. Refer to the included settings table to adjust the ESC for your driving conditions.

ESC PROGRAMMING PROCEDURE

Programming is accomplished using the SET button on the ON/OFF switch.

1. Connect a fully charged battery to the ESC.
2. Power ON the ESC using the ESC switch.
3. Press and hold the SET button for 3 seconds until the green LED flashes, then release the SET button.
4. Press the SET button once until the green LED blinks once in sequence, indicating programmable value 1 is currently selected.

Pressing the setup button once more moves to programmable value 2, etc. until the desired programmable value is reached. The system continues in a "loop".

5. When at the desired menu item, hold the SET button for 3 seconds until the red LED blinks.

The RED flashing sequence indicates the actual setting; for example one flash indicates value 1 is selected, two flashes indicates value 2, etc..

6. Press the setup button in sequence to select the desired programmable value. The system continues in a "loop."
7. Save the setting by holding the SET button for 3 seconds. The motor beeps once.
8. Power OFF the ESC then immediately power it ON. The setting change is stored.

Only one setting can be stored/saved at a time.

PROGRAMMABLE ITEMS Basic Items	PROGRAMMABLE VALUE			
	1	2	3	4
1 Running Mode	Forward w/ brake	Forward/Reverse w/ brake		
2 Drag Brake Force	0%	5%	10%	20%
3 Low Voltage Cutoff	non-protection	3.0V/Cell	3.2V/Cell	3.4V/Cell
4 Start Mode	Level 1	Level 2	Level 3	Level 4
5 Max Brake Force	25%	50%	75%	100%
6 Punch	Level 1	Level 2	Level 3	Level 4

DESCRIPTIONS

1. **Running Mode:**
 - *Forward Only with Brake*
Intended for competition use, this mode allows only forward and brake controls.
 - *Forward/Reverse with Brake*
This mode is the basic all-around mode, allowing forward, reverse and brake controls. To engage reverse while moving forward, apply the brake until the vehicle has come to a complete stop, release brake, then apply the brake again. While braking or in reverse, engaging the throttle will result in the vehicle immediately accelerating forward.
2. **Drag Brake Force**
Adjusts the amount of brake automatically applied when the throttle is returned to the neutral position. This simulates the engine braking effect of a full-scale vehicle, allowing improved turn-in and your vehicle's general response to controls.
3. **Low Voltage Cutoff**
This function helps to prevent battery over-discharge. The ESC continuously monitors the battery's voltage. If the voltage falls below the voltage threshold for 2 seconds, the output power shuts off and the red LED flashes twice repeatedly.
The cutoff threshold calculation is based on individual Li-Po cell voltage. For Ni-MH batteries, if the voltage battery pack is higher than 9.0V, it will be treated as a 3-cell Li-Po battery pack; if it is lower than 9.0V, it will be treated as a 2-cell Li-Po battery pack. Example: for a 8.0V Ni-MH battery pack used with a 2.6V/cell threshold, it will be treated as a 2-cell Li-Po battery pack and the low-voltage cut-off threshold will be 5.2V (2.6 x 2=5.2).
4. **Start Mode**
Sets the initial throttle punch when the car accelerates. Level 1 gives a very soft initial acceleration and Level 4 gives a stronger initial acceleration.
5. **Max Brake Force**
Adjusts the maximum braking force. A higher value provides stronger braking, but can also cause the wheels to lock, resulting in loss of control of the car.
6. **Punch**
Select from start mode Level 1 (Soft) to Level 9 (Very aggressive). If you choose Levels 7-9, use a high quality battery pack with powerful discharge ability. Without a high quality battery pack, the modes will not give a bursting start effect. If the motor does not run smoothly (i.e., trembling), choose a better battery or increase the gear rate.

ESC LED STATUS

- In the neutral position, no LEDs are lit.
- The red LED lights when the car is moving forward, reversing or braking (sensorless motor).
- The green LED lights when the car is moving forward, reversing or braking (sensored motor).
- The red LED flashes if the battery voltage has reached LVC.
- The red and green LEDs light alternately, indicating the ESC overheating protection is enabled.
- The red LED lights if the receiver signal is incorrect or missing.

TROUBLESHOOTING GUIDE

SYMPTOM	SOLUTION
ESC switch powered ON, but no motor function and no audible tone	Recharge or replace battery Ensure all connections are secure Repair or replace ESC switch or ESC Ensure ESC programming for battery is correct for your battery
Motor turns in the wrong direction	Change connections of any 2 motor wires to the ESC and ensure motor turns in the correct direction
Motor stops	When red ESC LED flashes, recharge or replace battery When red and green LEDs alternate flashing, let motor and ESC cool, changing set up or gearing to avoid overheating Ensure ESC programming is correct for voltage and battery Disconnect battery and let ESC cool Ensure ESC programming is not causing overheating Replace gearing Ensure gearing is not causing overheating
Motor accelerates irregularly	Replace with a high-power battery Replace battery Replace damaged wiring Adjust or replace gearing
Motor does not turn continuously in response to throttle	Replace wiring or motor Ensure good reception between transmitter and receiver Replace ESC
Steering servo operates but the motor does not run	Ensure all ESC programming matches your installed systems requirements for safety Ensure all receiver connections are correct and secure Test the motor apart from the vehicle system and repair or replace motor as needed Recharge or replace batteries Ensure all motor connections are secure Adjust throttle travel or other throttle settings on the transmitter and re-calibrate the ESC
Steering and motor do not function	Ensure all connections to receiver are correct and secure Refer to manufacturer's instructions to repair or replace transmitter Recharge or replace batteries
Vehicle does not operate at full speed	Recharge or replace batteries Ensure ESC programming is correct for voltage and battery Adjust transmitter settings, such as trim, throttle travel, etc. Ensure ESC settings are correct for system Re-calibrate ESC
Motor slows but will not stop	Adjust transmitter settings, such as trim, throttle travel, etc. Ensure ESC settings are correct for system Re-calibrate ESC
Decreased transmitter range	Repair or replace system antennas Repair or replace damaged wiring and electrical parts Move receiver or adjust antenna location so that no metal parts are between the antenna and the transmitter Recharge or replace batteries Refer to receiver and transmitter manufacturer's instructions to adjust reception or change to a free and open radio frequency

What this Warranty Covers

Horizon Hobby, LLC, (Horizon) warrants to the original purchaser that the product purchased (the "Product") will be free from defects in materials and workmanship at the date of purchase.

What is Not Covered

This warranty is not transferable and does not cover (i) cosmetic damage, (ii) damage due to acts of God, accident, misuse, abuse, negligence, commercial use, or due to improper use, installation, operation or maintenance, (iii) modification of or to any part of the Product, (iv) attempted service by anyone other than a Horizon Hobby authorized service center, (v) Product not purchased from an authorized Horizon dealer, or (vi) Product not compliant with applicable technical regulations, or (vii) use that violates any applicable laws, rules, or regulations.

OTHER THAN THE EXPRESS WARRANTY ABOVE, HORIZON MAKES NO OTHER WARRANTY OR REPRESENTATION, AND HEREBY DISCLAIMS ANY AND ALL IMPLIED WARRANTIES, INCLUDING, WITHOUT LIMITATION, THE IMPLIED WARRANTIES OF NON-INFRINGEMENT, MERCHANTABILITY AND FITNESS FOR A PARTICULAR PURPOSE. THE PURCHASER ACKNOWLEDGES THAT THEY ALONE HAVE DETERMINED THAT THE PRODUCT WILL SUITABLY MEET THE REQUIREMENTS OF THE PURCHASER'S INTENDED USE.

Purchaser's Remedy

Horizon's sole obligation and purchaser's sole and exclusive remedy shall be that Horizon will, at its option, either (i) service, or (ii) replace, any Product determined by Horizon to be defective. Horizon reserves the right to inspect any and all Product(s) involved in a warranty claim. Service or replacement decisions are at the sole discretion of Horizon. Proof of purchase is required for all warranty claims. SERVICE OR REPLACEMENT AS PROVIDED UNDER THIS WARRANTY IS THE PURCHASER'S SOLE AND EXCLUSIVE REMEDY.

Limitation of Liability

HORIZON SHALL NOT BE LIABLE FOR SPECIAL, INDIRECT, INCIDENTAL OR CONSEQUENTIAL DAMAGES, LOSS OF PROFITS OR PRODUCTION OR COMMERCIAL LOSS IN ANY WAY, REGARDLESS OF WHETHER SUCH CLAIM IS BASED IN CONTRACT, WARRANTY, TORT, NEGLIGENCE, STRICT LIABILITY OR ANY OTHER THEORY OF LIABILITY, EVEN IF HORIZON HAS BEEN ADVISED OF THE POSSIBILITY OF SUCH DAMAGES. Further, in no event shall the liability of Horizon exceed the individual price of the Product on which liability is asserted. As Horizon has no control over use, setup, final assembly, modification or misuse, no liability shall be assumed nor accepted for any resulting damage or injury. By the act of use, setup or assembly, the user accepts all resulting liability. If you as the purchaser or user are not prepared to accept the liability associated with the use of the Product, purchaser is advised to return the Product immediately in new and unused condition to the place of purchase.

Law

These terms are governed by Illinois law (without regard to conflict of law principals). This warranty gives you specific legal rights, and you may also have other rights which vary from state to state. Horizon reserves the right to change or modify this warranty at any time without notice.

WARRANTY SERVICES

Questions, Assistance, and Services

Your local hobby store and/or place of purchase cannot provide warranty support or service. Once assembly, setup or use of the Product has been started, you must contact your local distributor or Horizon directly. This will enable Horizon to better answer your questions and service you in the event that you may need any assistance. For questions or assistance, please visit our website at www.horizonhobby.com, submit a Product Support Inquiry, or

LIMITED WARRANTY

call the toll free telephone number referenced in the Warranty and Service Contact Information section to speak with a Product Support representative.

Inspection or Services

If this Product needs to be inspected or serviced and is compliant in the country you live and use the Product in, please use the Horizon Online Service Request submission process found on our website or call Horizon to obtain a Return Merchandise Authorization (RMA) number. Pack the Product securely using a shipping carton. Please note that original boxes may be included, but are not designed to withstand the rigors of shipping without additional protection. Ship via a carrier that provides tracking and insurance for lost or damaged parcels, as Horizon is not responsible for merchandise until it arrives and is accepted at our facility. An Online Service Request is available at http://www.horizonhobby.com/content/_render-service-center_render-service-center. If you do not have internet access, please contact Horizon Product Support to obtain a RMA number along with instructions for submitting your product for service. When calling Horizon, you will be asked to provide your complete name, street address, email address and phone number where you can be reached during business hours. When sending product into Horizon, please include your RMA number, a list of the included items, and a brief summary of the problem. A copy of your original sales receipt must be included for warranty consideration. Be sure your name, address, and RMA number are clearly written on the outside of the shipping carton.

NOTICE: Do not ship LiPo batteries to Horizon. If you have any issue with a LiPo battery, please contact the appropriate Horizon Product Support office.

Warranty Requirements

For Warranty consideration, you must include your original sales receipt verifying the proof-of-purchase date. Provided warranty conditions have been met, your Product will be serviced or replaced free of charge. Service or replacement decisions are at the sole discretion of Horizon.

Non-Warranty Service

Should your service not be covered by warranty, service will be completed and payment will be required without notification or estimate of the expense unless the expense exceeds 50% of the retail purchase cost. By submitting the item for service you are agreeing to payment of the service without notification. Service estimates are available upon request. You must include this request with your item submitted for service. Non-warranty service estimates will be billed a minimum of ½ hour of labor. In addition you will be billed for return freight. Horizon accepts money orders and cashier's checks, as well as Visa, MasterCard, American Express, and Discover cards. By submitting any item to Horizon for service, you are agreeing to Horizon's Terms and Conditions found on our website http://www.horizonhobby.com/content/_render-service-center_render-service-center.

ATTENTION: Horizon service is limited to Product compliant in the country of use and ownership. If received, a non-compliant Product will not be serviced. Further, the sender will be responsible for arranging return shipment of the un-serviced Product, through a carrier of the sender's choice and at the sender's expense. Horizon will hold non-compliant Product for a period of 60 days from notification, after which it will be discarded.

WARRANTY AND SERVICE CONTACT INFORMATION

Country of Purchase	Horizon Hobby	Contact Information	Address
United States of America	Horizon Service Center (Repairs and Repair Requests)	servicecenter.horizonhobby.com/ RequestForm/	2904 Research Rd Champaign, Illinois, 61822 USA
	Horizon Product Support (Product Technical Assistance)	productsupport@horizonhobby.com 877-504-0233	
	Sales	websales@horizonhobby.com 800-338-4639	
European Union	Horizon Technischer Service	service@horizonhobby.eu	Hanskamping 9 D 22865 Barsbüttel, Germany
	Sales: Horizon Hobby GmbH	+49 (0) 4121 2655 100	

COMPLIANCE INFORMATION FOR THE EUROPEAN UNION

CE EU Compliance Statement: Horizon Hobby, LLC hereby declares that this product is in compliance with the essential requirements and other relevant provisions of the EMC Directive.

A copy of the EU Declaration of Conformity is available online at: <http://www.horizonhobby.com/content/support-render-compliance>.



Instructions for disposal of WEEE by users in the European Union

This product must not be disposed of with other waste. Instead, it is the user's responsibility to dispose of their waste equipment by handing it over to a designated collections point for the recycling of waste electrical and electronic equipment. The separate collection and recycling of your waste equipment at the time of disposal will help to conserve natural resources and ensure that it is recycled in a manner that protects human health and the environment. For more information about where you can drop off your waste equipment for recycling, please contact your local city office, your household waste disposal service or where you purchased the product.