

RC HOBBY

1:10 ATLAS 4X4

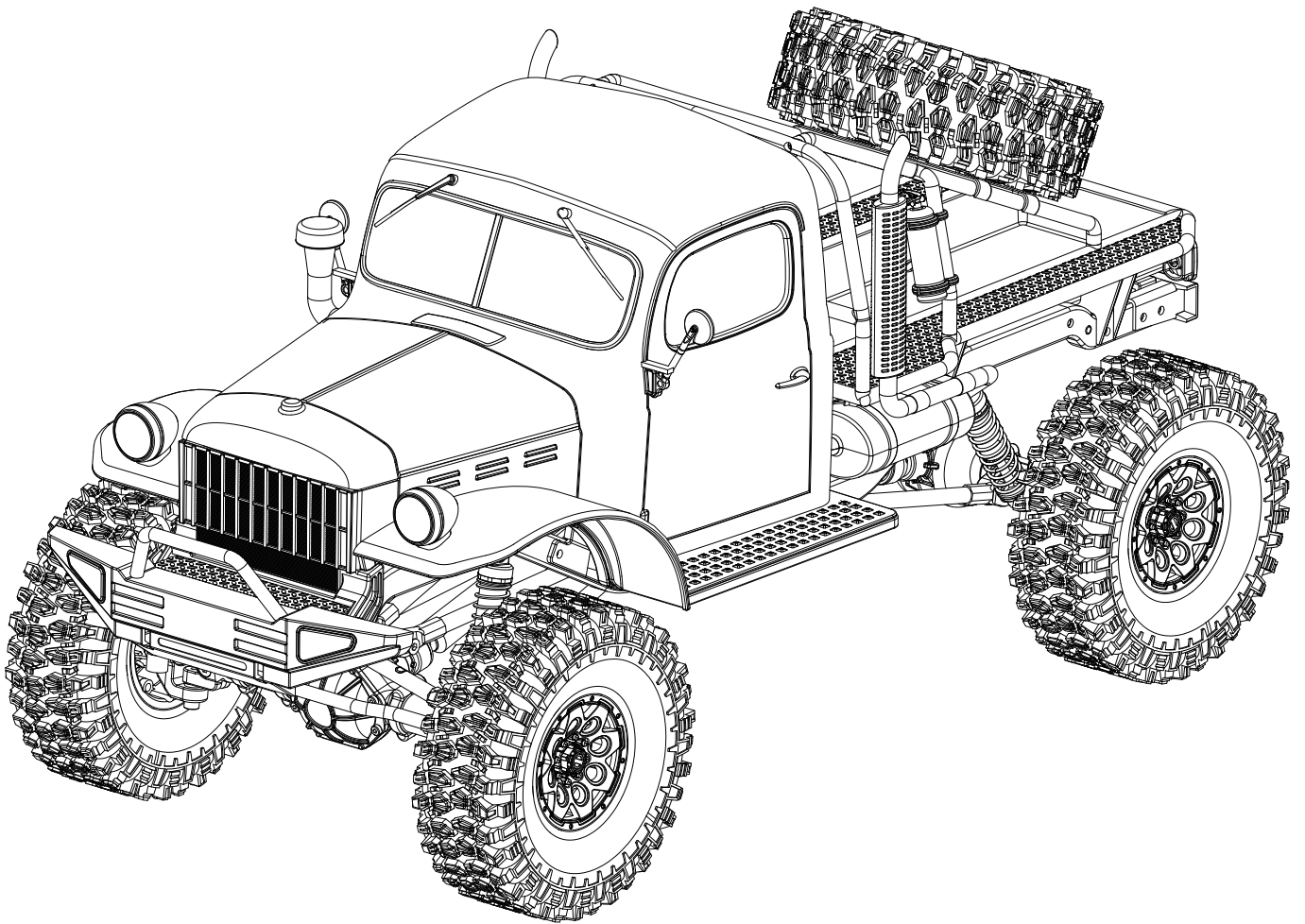

MAN-G0189

Instruction Manual

操作手册

Introduction 指引

Thank you for purchasing our products.

This manual is written to assist you in properly operating, maintaining and repairing the vehicle. As many of the components used are unique to this product, please retain this manual as a future reference. Composed of precision-made components, this product is not a toy, thus it is not suited for children under 14 years of age. Minors should be accompanied by an adult when operating. Failure to operate or maintain this product in a safe manner can result in bodily harm. It is the owner responsibility to operate this product in a safe manner. ROCHOBBY and its distributors are not responsible in any way for any and all bodily harm and/ or property damage that may result from the use of this product.

感谢您购买我们的产品。

本手册旨在帮助您正确操作、维护和修理车辆。由于本品所涉部件多数为特有部件，请保留本手册作为未来参考之用。

本产品由精密部件组成，并非玩具，因此不适合 14 岁以下的少年或儿童使用。未成年人操作时应有成人陪同。未能以安全的方式操作或维护本产品可能会导致人身伤害。以安全的方式操作本产品是所有者的责任。ROCHOBBY及其分销商对使用本产品可能导致的任何和所有人身伤害和/或财产损失概不负责。

Safety, precautions and warnings 安全、预防措施及警告

- Replace damaged components with original factory-parts.
- Pay special attention to the polarity of all vehicle wiring.
- Use common sense when selecting the environment to operate your vehicle. Do not operate near power cables, cellular/radio towers, water or unstable terrain. The operator is solely responsible for their actions.
- The product is composed of precision electrical components. It is critical to keep the product away from moisture and other contaminants.
- Always check the radio range of the vehicle prior to operation in order to prevent radio loss or interference.
- Operate this product within your ability. If the vehicle is dangerous to retrieve, it never worth the risk.
- Always turn on the transmitter before connecting the battery on the model. When turning off the model, always disconnect the battery first, and then turn off the model, always disconnect the battery first, and then turn off the transmitter. If this order is reversed, the model may become uncontrollable and cause serious damage.
- Never allow transmitter batteries to run low as it may cause loss of vehicle control.
- Plastics on the vehicle are susceptible to damage or deformation due to extreme heat and cold climate. Do not store the model near any source of heat such as oven or heater. Store the model indoors, in a climate-controlled, room temperature environment.
- 请使用原厂部件更换损坏的部件。
- 特别注意所有车辆接线的正负极。
- 务必选择合适的环境操作遥控模型，所选环境需远离电缆、无线电塔、水域及不稳定地形。本品操作者对其行为全权负责。
- 本品由精密电子部件构成。请勿将本品暴露于潮湿的环境或者其他污染物中，以免损坏。
- 确保每次操作前检查车辆的无线接收范围，以防止无线信号丢失或受干扰。
- 在您的能力范围内操作此产品。在任何时候，如果车辆操作有危险，则绝对不值得冒险。
- 通电方式：务必先开遥控器再将车通电。断电方式：务必先将车断电再关遥控器。以上顺序如逆转，则可能引起遥控模型失控，导致人身伤害或财产损失。
- 遥控器电池电量不足时，不要操作模型车，以免失控。
- 模型产品上的塑胶件容易因极冷或极热气候出现变形或损坏的状况。所以请将模型产品存放在气候受控的室温环境中，切勿靠近任何热源，如烤箱或暖器等。

SAFETY PRECAUTIONS 安全保障措施

This product is not a toy! (14+) Recommended for ages 14 and up. Adult supervision required for ages under 14 years old. Contains small parts, keep out of reach of children 3 years of age and younger.

使用前请仔细阅读本手册。我们不对任何故意损坏或不当使用负责。这个产品不是玩具！建议14岁及以上者使用。14岁以下的用户，需要在成年人监督下使用。本产品部分包含小零件，请务必保证3岁及以下儿童不能接触本产品。



CE Warning

The antenna(s) used for this transmitter must be installed to provide a separation distance of at least 20 cm from all persons and must not be co-located or operating in conjunction with any other transmitter. End-users and installers must be provided with antenna installation instructions and transmitter operating conditions for satisfying RF exposure compliance.

Appendix 1 FCC Statement

This equipment has been tested and found to comply with the limits for a Class B digital device pursuant to part 15 of the FCC rules. These limits are designed to provide reasonable protection against harmful interference in a residential installation. This equipment generates, uses and can radiate radio frequency energy and, if not installed and used in accordance with the instructions, may cause harmful interference to radio communications. However, there is no guarantee that interference will not occur in a particular installation. If this equipment does cause harmful interference to radio or television reception, which can be determined by turning the equipment off and on, the user is encouraged to try to correct the interference by one or more of the following measures:

- Reorient or relocate the receiving antenna.
- Increase the separation between the equipment and receiver.
- Connect the equipment into an outlet on a circuit different from that to which the receiver is connected.
- Consult the dealer or an experienced radio/TV technician for help.

To assure continued compliance, any changes or modifications not expressly approved by the party responsible for compliance could void the user's authority to operate this equipment.

This equipment complies with Part 15 of the FCC Rules. Operation is subject to the following two conditions:

- (1) This device may not cause harmful interference.
- (2) This device must accept any interference received, including interference that may cause undesired operation.

Caution!

The manufacturer is not responsible for any radio or TV interference caused by unauthorized modifications to this equipment. Such modifications could void the user authority to operate the equipment.

1. The antenna(s) used for this transmitter must be installed to provide a separation distance of at least 20 cm from all persons and must not be co-located or operating in conjunction with any other transmitter. End-users and installers must be provided with antenna installation instructions and transmitter operating conditions for satisfying RF exposure compliance.

2. Move all your channels to the desired position.

3. Select [All channels] and then [Yes] in the confirmation box.

Declaration of Conformity (DoC)

We,
Add:Room 701, Building B, Xiangshan Bay Industrial
Zone, Xiangshan Road 142, Luotian Community,
Songgang Street, Baoan District, Shenzhen

Phone:0755-61811796
Web:www.rochobby.com



declare under our responsibility that the product:

Type of Equipment: Driving System & 2.4GHz Control System

Brand Name: ROCHOBBY

Compatiable for cars: 1: 10 ATLAS 4x4

Equipment Model: 11036

to which this declaration relates is in conformity with the essential requirements and other relevant requirements of the Directive 2014/53/EU, EMC Directive 2014/30/EU, EMC Directive 2014/53/EU, FCC Identifier N4ZG4P00 , EU RoHS Directive 2011/65/EU and Council Directive 2014/30/EU. The product is in conformity with following standards and/or other normative documents:

ETSI EN 301 489-1 V2.2.3(2019-11)

ETSI EN 301 489-17 V3.2.4(2020-09)

EN 55032:2015+A11:2020

EN 55035:2017+A11:2020

EN61000-3-2:2014

EN61000-3-3:2013

EN : 62479:2010

ETSI EN 300 328 V2.2.2 (2019-07)

About Model 产品介绍

During World War II, almost all automakers supplied trucks for the military. Military trucks needed to drive on rough, non-paved roads, and had higher requirements for off-road capability, reliability, and durability than civilian vehicles. Based on the manufacturing experience during the war, the post-war trucks paid great attention to four-wheel drive technology and carrying capacity. In addition to the most basic transportation purposes, they could be transformed into fire trucks, cranes, ambulances, rescue vehicles, etc. Though the smoke of war has gone, the truck's powerful off-road performance has not retreated. Off-road enthusiasts drive all kinds of trucks to fight against swamps, rainforests, hills, deserts and more.

This 1/10 Atlas is designed precisely in the form of an off-road truck racer. The car body is moulded with PC plastic, which is light in weight and has a low center of gravity; the nylon roll cage at the back can protect the car shell during rollovers. The rigid metal frame and four-link suspension system ensure strong climbing ability. The chassis has proven reliability. In both dynamic and static aspects, the real vehicle has been painstakingly restored.

二战期间，几乎所有的汽车制造商都为军队供应卡车，军用卡车需要在崎岖的非铺装路面行驶，对越野能力、可靠性和耐久性的要求都比民用车辆高。得益于战时的制造经验，战后的卡车十分注重四轮驱动技术和运载能力，她们除了最基本的运输用途以外，通过有针对性的改装，可以摇身一变成为消防车、吊车、救护车和救援车。虽然战争的硝烟散去，但卡车强悍的越野性能却并未隐退。越野爱好者们驾驶着各式各样的卡车征战沼泽、雨林、山丘、荒漠...

这款 1/10模型“斗牛者”正是以卡车越野赛为目标的赛车形态。车壳以PC材料吸塑成形，重量轻，重心低。后面的尼龙防滚架可以在翻滚时起到保护车壳的作用。坚固的金属大梁搭配四连杆悬挂系统，使底盘拥有强大的攀爬能力和久经考验的可靠性，在动态和静态两个方面还原真车。

Features 产品特点

- READY SET
- BALL BEARINGS FULL SET
- METAL GEAR FULL SET
- NYLON ROLL CAGE
- METAL FRAME
- FOUR-LINK SUSPENSION
- RAPID SEPARATION CAR BODY
- PAINTED BODY
- ORIGINAL PERSONALIZED STICKERS
- 120mm AT TIRE
- 35T 550 MOTOR
- 2.4GHz RADIO SYSTEM
- 组装完成品
- 全车滚珠轴承
- 全车金属齿轮
- 尼龙防滚架
- 金属大梁
- 四连杆悬挂
- 车壳快拆结构
- 喷涂完成车壳
- 原创个性化贴纸
- 120mm全地形轮胎
- 35T 550大扭力电机
- 2.4GHz遥控系统

Specification 产品参数

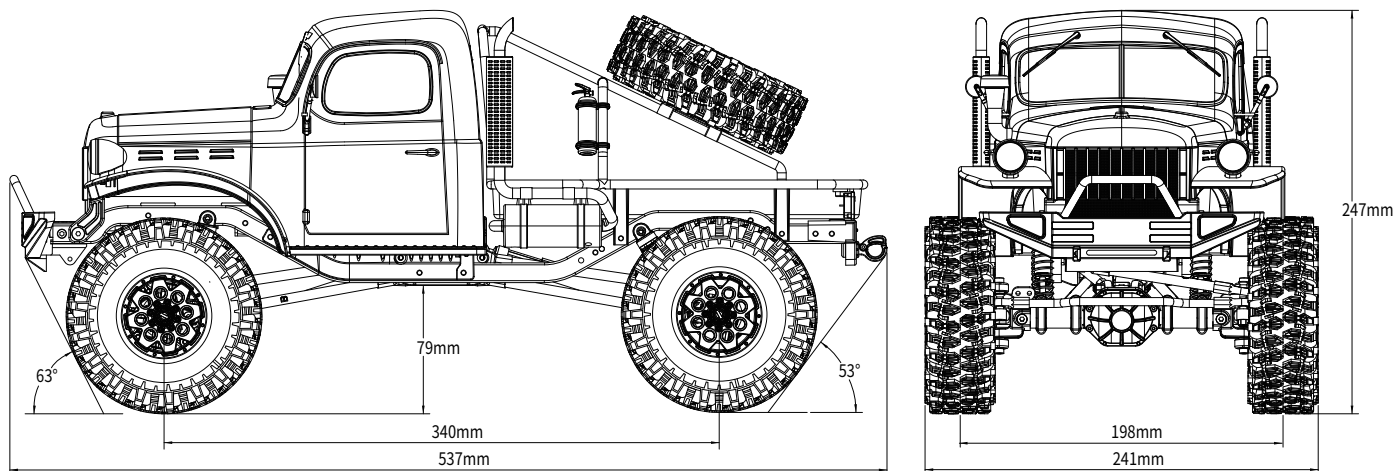

- Length:537mm
- Width:241mm
- Height:247mm
- Wheelbase:340mm
- Tire F/R :Φ 120mm
- Approach Angle:63°
- Departure Angle:53°
- Ground Clearance: 79mm
- Motor: 35T 550 Brushed motor
- Remote control distance: 80m
- Remote control: 2.4GHz Transmitter (Fibre Style) & Receiver Set

- 车长: 537mm
- 车宽: 241mm
- 车高: 247mm
- 轴距: 340mm
- 轮胎: Φ 120mm
- 接近角 : 63°
- 离去角 : 53°
- 离地间隙: 79mm
- 电机 : 35T 550有刷电机
- 遥控距离 : 80m
- 遥控 : 2.4GHz 发射器 (碳纤维纹风格) + 接收器

Transmitter intruction 发射机概览

The FS-G4P is a simple 4 channel transmitter using the latest AFHDS 2.4GHz ATN frequency hopping technology. Designed to be sleek, passionate and powerful for entry level enthusiasts.

FS-G4P是一款使用富斯最新自主研发的2.4GHz ANT蚂蚁版自动跳频数字系统的简版4通道发射机，外观采用跑车元素彰显速度、激情和力量，该款发射机还具备初学者模式方便入门玩家使用。

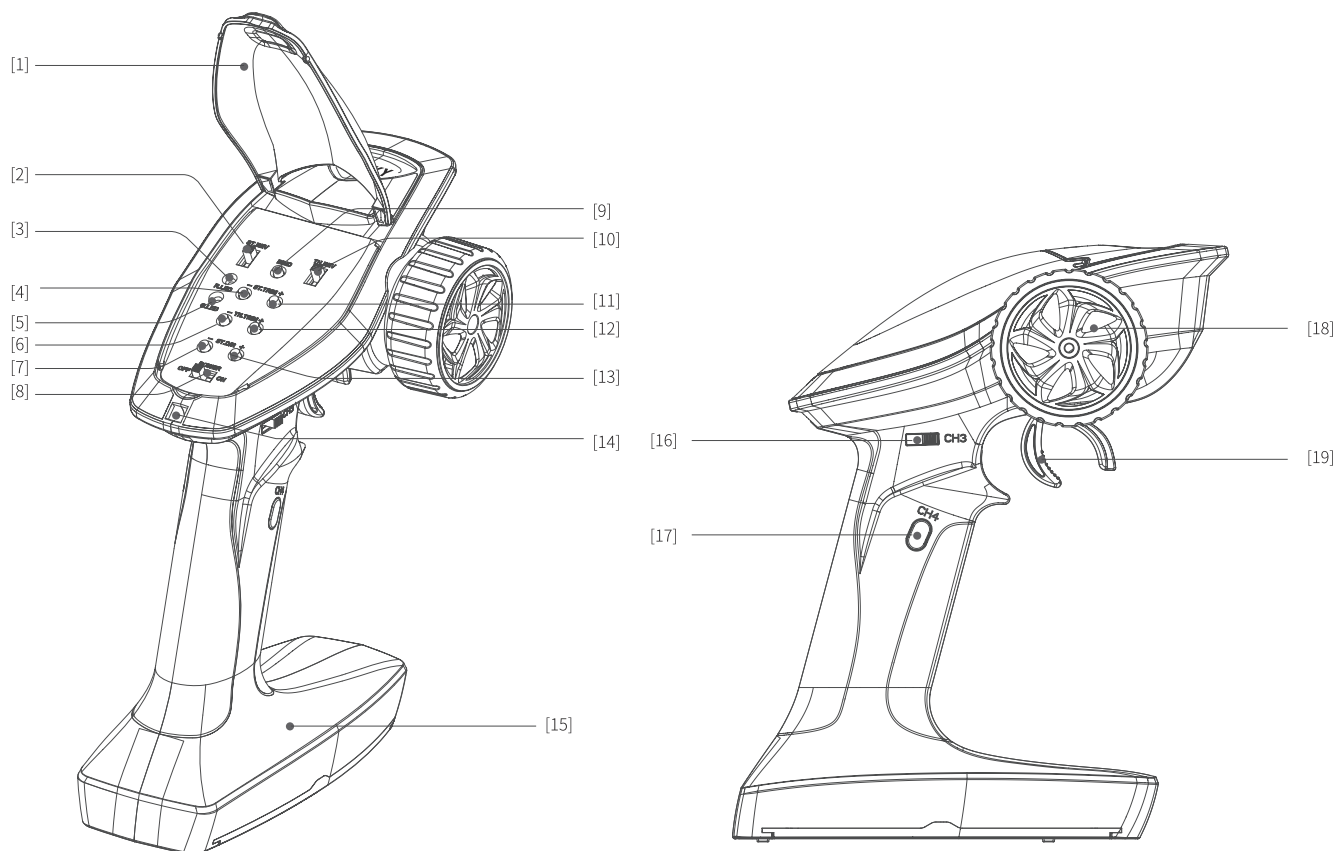







[1]	Panel Flip Cover 功能面板保护盖	[11]	Steering Trim (ST.TRIM +) 方向微调按键 (ST.TRIM+)
[2]	Steering Reverse Switch (ST.REV) 方向倒置开关 (ST.REV)	[12]	Throttle Trim (TH.TRIM +) 油门微调按键 (TH.TRIM+)
[3]	Power indicator LED (R. LED) 电源指示灯红色LED (R.LED)	[13]	Steering D/R (ST.D / R +) 方向比例调节按键 (ST.D/R+)
[4]	Steering Trim (ST.TRIM-) 方向微调按键 (ST.TRIM-)	[14]	Lanyard Eye 挂绳孔
[5]	Status indicator green LED (G.LED) 状态指示灯绿色LED (G.LED)	[15]	Base, 4 * AA battery compartment 底座, 4*AA电池仓
[6]	Throttle Trim (TH.TRIM-) 油门微调按键 (TH.TRIM-)	[16]	Three-position switch (CH3) 三档拨动开关 (CH3)
[7]	Steering D/R (ST.D / R-) 方向比例调节按键 (ST.D/R-)	[17]	Button (CH4) 按键开关 (CH4)
[8]	Power Switch 电源开关	[18]	Wheel Angle, the maximum rotation of the steering wheel is 35 degrees from center to left or right (CH1) 方向手轮, 左右各35度 (CH1)
[9]	Bind Button (BIND) 对码按键 (BIND)	[19]	Throttle trigger, has a total throw of 12 degrees, 12.5 degrees for backward (CH2) 油门扣机, 前25度后12.5度 (CH2)
[10]	Throttle Reverse (TH.REV) 油门倒置开关 (TH.REV)		

Getting Started 使用前准备

Before operation, install the battery and connect the system as instructed below.

开始操作前，请按照本章的顺序和指引安装电池、连接设备。

Transmitter Battery Installation 发射机电池安装

 Danger 危险	Only use specified battery (X4 AA batteries). 仅使用厂家指定的电池。
 Danger 危险	Do not open, disassemble, or attempt to repair the battery. 请勿打开、拆卸或自行维修电池。
 Danger 危险	Do not crush/puncture the battery, or short the external contacts. 请勿挤压、刺穿或接触电池的金属端子。
 Danger 危险	Do not expose to excessive heat or liquids. 请勿将电池置于高温环境或液体中。
 Danger 危险	Do not drop the battery or expose to strong shocks or vibrations. 如果不按照说明方法操作，可能导致操作者或他人遭受较大伤害。
 Danger 危险	Always store the battery in a cool, dry place. 请将电池存放在干燥阴凉的环境中。
 Danger 危险	Do not use the battery if damaged. 如果电池损坏，请立即停止使用。

Battery Type: AA

Battery Installation:

1. Open the battery compartment cover.
2. Insert 4 fully-charged AA batteries into the compartment. Make sure that the battery makes good contact with the battery compartment's contacts.
3. Replace battery compartment cover.

Low battery alarm: When the battery is lower than 4.2V, the G.LED on the panel will flash slowly.

电池类型使用: AA电池

请按照以下步骤安装发射机电池：

1. 打开电池仓盖。
2. 将4颗电量充足的AA电池装入电池仓内，确保电池上的金属端子与电池仓内的金属端子接触。
3. 盖好电池仓盖。

低电量报警:当电量低于4.2V时，面板上的G.LED慢闪报警提示。

Instructions 操作指引

After setting up, follow the instructions below to operate the system.

准备操作完成后，您可以按照本章指引开始使用本产品。

1. Power ON 开机

Follow the steps below to turn on the transmitter:



1. Check to make sure that that battery is fully charged and installed correctly.
2. Toggle the switch to the [ON] position. When active the R.LED will be lit.
3. Connect the receiver to power.

For safety always power on the transmitter before the receiver.

请按照以下步骤进行开机:

1. 检查系统状态，确保 :电池电量充足且安装正确。
2. 将开关拨到 [ON] 位置，R.LED 灯常亮。
3. 连接接收机电源。

注意：为保障模型及人员安全，使用时请先打开发射机再给接收机上电。

 Note 警告	Operate with caution in order to avoid damage or injury. 此时系统已启动，请谨慎操作,否则可能导致产品损坏或人员伤亡。
 Note 警告	Make sure that the throttle is at its lowest position and the switches are set to their up position. 为了您的安全请将发射机开关和油门打到安全位置。

2. Binding(The transmitter and receiver have already been bound at the factory) 对码 (发射机和接收机在出厂前已对码成功。)

If the transmitter or receiver need to be replaced, bind follow these steps:

1. Turn on the transmitter while holding the bind button to enter bind mode. G.LED will start flashing quickly:
Once in bind mode release the bind button.
2. The receiver will enter bind mode atomically when powered on.
3. Once binding is successful the receiver' s LED will flash slowly and the transmitter' s LED will remain solid after being rebooted.

Note: When binding, put the transmitter into bind mode first, then the receiver.

- Applicable to the FS-G4P transmitter and the FS-R4P receiver. Different receivers have different bind procedures. For more information visit the ROC Hobby website for manuals and other related information.
- Product information is updated regularly, please visit our website for more information.

如需更换其他的发射机或接收机，请按照如下步骤进行对码:

1. 按住对码按钮打开发射机进入对码模式。G.LED 将开始快速闪烁。一旦进入对码模式，松开对码按钮。
2. 接收机上电自动进入对码；3. 对码成功接收机 LED 指示灯慢闪，发射机关机重启接收机指示灯常亮；

注意：对码时请先将发射机进入对码状态，再将接收机进入对码状态。

- 此对码步骤仅适用于 FS-G4P 发射机与 FS-R4P 接收机对码，不同的接收机对码方式不同。
- 由于产品处于不断更新状态，请进入 我们官网查询最新的发射机与接收机兼容表单。

3.Stick Calibration(This function is used to set the neutral position for throttle and wheel) 遥感校准 (该功能可以用于方向手轮和油门扳机的中位角度修正。)

Every transmitter is calibrated before leaving the factory, however if recalibration is required, please follow these steps:

1. Turn and hold the wheel as far clockwise as it will turn, hold the throttle all the way forward, then turn on the transmitter in calibration mode.
 - The R.LED and G.LED will flash twice.
2. Calibrate wheel: Turn the wheel completely clockwise, then completely counterclockwise.
 - When calibration is completed the R.LED will be off.
3. Trigger calibration: Pull the trigger back then forward as far as it will go.
 - When calibration is completed the G.LED will be off.
4. Once calibration is complete press the bind key to save and exit.

发射机在出厂前已校准完成，如需要重新校准，请按照以下步骤执行：

1. 同步将手轮顺时针打到最大、扣机往前推到底并开机，进入校准模式功能；
 - R.LED 和 G.LED 二闪一灭
2. 手轮校准：操作手轮顺时针和逆时针转到最大最小；
 - R.LED 灭
3. 扣机校准：往前往后推到最大最小；
 - G.LED 灭
4. 校准完成后按“BIND”键退出并保存数据。

4.Power OFF 关机

Follow the steps below to turn off the system:

1. Disconnect the receiver power.
2. Toggle the transmitter's power switch to the off position.

请按照以下步骤进行关机:

1. 断开接收机电源。
2. 将开关拨到[OFF]位置，使发射机关闭。



Danger
危险

Make sure to disconnect the receiver power before turning off the transmitter. Failure to do so may lead to damage or serious injury.

关闭时，请务必先关闭接收机电源，再关闭发射机，否则可能导致模型损坏、人员受伤。

Channel Description 通道说明

The transmitter outputs a total of 4 channels, which are allocated as follows:

- | | |
|-------------------------------|--------------------------|
| 1. CH1: Steering Wheel | 2. CH2: Throttle Trigger |
| 3. CH3: Three-position Switch | 4. CH4: Reset Button |

Note: By default the output of CH4 is 1000us, pressing the button will toggle between 1000 and 2000us

该发射机共输出4个通道，分配如下：

- | | |
|-------------|-------------|
| 1. CH1：方向手轮 | 2. CH2：油门扣机 |
| 3. CH3：三档开关 | 4. CH4：复位按键 |

注意：CH4 按键开机默认输出 1000us，按压操作一下通道值翻转 - 次，数值在 1000us/2000us 之间互相切换。

Channel Reverse 通道反向（该功能用于调整舵机或马达的动作方向。）

This function is used to adjust each channels direction of movement in relation to it's input.

The ST.REV / TH.REV switches are the reverse buttons for CH1 and CH2. If the switch is up it indicates reverse, and the down indicates normal.

按键ST.REV/TH.REV分别为CH1、CH2通道反向按键，开关上拨表示反向，下拨表示正常。

Trims 微调

The ST.TRIM is the trims for CH1 (steering),and can be multiplexed as trims of CH3 and CH4.

For multiplexing switching mode, refer to [5 Mode Switching].

TH.TRIM is the trims for CH2(throttle).

Adjustment range: -120us- + 120us, each step is 4us;

ST.TRIM + / TH.TRIM +: Increases adjustment step;

ST.TRIM- / TH.TRIM-: Decreases adjustment step.

LED Indicator:

When using the trim keys the G.LED will flash slowly on short presses and quickly on long presses.

When the trim adjustment value is at the neutral position, the G.LED will flash twice slowly.

When the trim adjustment value is at both ends (+ 120us / -120us), the trim adjustment is at its maximum and as such G.LED will not flash(If the fine adjustment value has been adjusted to + 120us, then press ST.TRIM + / TH.TRIM + key is invalid and G.LED has no indications.)

ST.TRIM 为 CH1 方向微调，可复用为 CH3、CH4 微调，复用切换方式见 [5 模式切换]；

TH.TRIM 为 CH2 油门微调。

调节范围：-120us-+120us，微调步进为 4us；

ST.TRIM+/TH.TRIM+：增大微调值；

ST.TRIM-/TH.TRIM-：减少微调值。

LED指示情况:

操作一次微调键 G.LED 闪烁一次，长按快闪

当微调值位于中点时 G.LED 慢闪 2 下

当微调值位于两端时 (+120us/-120us)，微调无效且 G.LED 无指示（如微调值已调至 +120us，此时按 ST.TRIM+/TH.TRIM+ 键无效且 G.LED 无指示）

D/R 舵量调节

ST.D / R is for servo travel adjustment, which can be multiplexed as CH2 (throttle), CH3, CH4 servo travel adjustment, refer to [5 Mode Switch] for multiplex switching mode;

Adjustment range: 0-120%(the default is 100%), the step is 5%.

ST.D / R +: Increases servo travel.

ST.D / R -: Decreases servo travel.

LED Indicator:

When using the trim keys the G.LED will flash slowly on short presses and quickly on long presses.

When the ratio value is at both ends (0/120%), the ST.D / R button is at its maximum and as such G.LED will not flash(if the ratio value has been adjusted to 120%, then press ST.D/R+ key is invalid and G.LED has Instructions)

ST.D/R 为方向舵量调节，可复用为 CH2 (油门)、CH3、CH4 舵量调节，复用切换方式见 [5 模式切换]；

调节范围：0-120% (默认 100%)，步进为 5%；

ST.D/R+：增加舵量；

ST.D/R-：减小舵量

LED 指示情况：

操作一次按键 G.LED 闪烁一次，长按快闪

当比例值位于两端时(0/100%)，按键无效且G.LED无指示(如比例值已调至100%，此时按ST.D/R+键无效且G.LED无指示)

Mode switching 模式切换

This function is for reusing the ST.TRIM and ST.D / R buttons for different channels (Refer to [Trims] and [D/R]).

Function setting:

Under normal power-on, quickly press the Bind button twice (within 1 second) to cycle through modes 1, 2, 3, and 4. The default setting when powering on is mode 1.

Mode 1: G.LED flashes slowly once, ST.TRIM is CH1 trim adjustment, ST.D / R is servo travel adjustment.

Mode 2: G.LED flashes twice slowly, ST.TRIM is CH1 trim adjustment, ST.D / R is CH2 servo travel adjustment.

Mode 3: G.LED flashes three times slowly, ST.TRIM is CH3 trim adjustment, ST.D / R is CH3 servo travel adjustment.

Mode 4: G.LED flashes slowly four times, ST.TRIM is CH4 trim adjustment, ST.D / R is CH4 servo travel adjustment.

此功能用于将 ST.TRIM 及 ST.D/R 按键复用于其他通道 (详见 [微调]、[舵量调节])。

功能设置：正常开机状态下快速短按两下对码按键 (BIND) (1S 内) 即可循环切换模式一、二、三、四，开机默认为模式一。

模式一：G.LED 慢闪一次提示，ST.TRIM 为 CH1 微调，ST.D/R 为方向舵量调节；

模式二：G.LED 慢闪二次提示，ST.TRIM 为 CH1 微调，ST.D/R 为 CH2 舵量调节；

模式三：G.LED 慢闪三次提示，ST.TRIM 为 CH3 微调，ST.D/R 为 CH3 舵量调节；

模式四：G.LED 慢闪四次提示，ST.TRIM 为 CH4 微调，ST.D/R 为 CH4 舵量调节；

Failsafe 失控保护

This function dictates what the receiver will do in the event that it loses signal from the transmitter, this includes servo position etc.

Function settings:

1. Turn on the transmitter and make sure it is connected to the receiver.

2. Hold the control surface at the desired failsafe position.

3. Press and hold the bind button for 3 seconds, if the G.LED starts flashes for 2 seconds, indicating that the settings are successful.

Note: The fail-safe function has no default set at the factory and as such must be set manually. If no failsafe setting has been set, then the receiver will not output anything when signal is lost.

此功能用于当接收机无法正常收到发射机的信号时，对应通道舵机移动至预先设定的位置，保护模型和操作人员的安全。

功能设置：发射机开机正常通讯状态下，将需要设置的通道保持在需要设定的失控保护值位置保持不动，同时长按对码键(BIND) 3S，G.LED 闪烁 2S 表示设置成功，即当接收机无法接收信号后，将按照设定的失控值输出。

注意：失控保护出厂默认无任何设置，无设置时失控接收机无有效信号输出。

System Functions 遥控系统功能

Beginner Mode 初学者模式

Beginner mode is designed for the people who is new to the hobby.

In this mode the throttle has been limited to 50 percent, The channel range defaults has been set to 1250~1500~1750us.

Function settings:

To switch between beginner and normal modes, press and hold the CH4 button while turning the steering wheel completely counterclockwise as far as it can, and at the same time, power on the transmitter.

Note: By default, the system is set to normal mode. If the system has set to beginner mode.

The G.LED will be in a state of two-time flashing and on off, and keep the state for 3 seconds during power on.

初学者模式比较适合入门级玩家，通过对油门幅度的控制来提高操作的安全性。

初学者模式模式油门输出仅为 50% ，即 CH2 通道范围默认为 1250~1500~1750us。

功能设置：

按住 CH4 按键，同时方向手轮逆时针打到底 维持以上动作同时开机

注意：出厂默认为正常模式，开机时 G.LED 灯二闪一灭持续 3S，代表此次进入初学者模式。

Instructions 遥控产品规格

Transmitter specification 发射机规格

- Product Mode: FS-G4P
 - Channels: 4
 - Model Type: Car
 - RF: 2.4GHz
 - RF Power: <20dBm
 - 2.4GHz Protocol: ANT
 - Distance: >200m (Ground)
 - Channel Resolution: 1024
 - Battery: 6V DC 1.5AA*4
 - Charging Interface: NO
 - Life time: According to battery type
 - Low Voltage Warning: <4.2V
 - Antenna Type: Built-in single antenna
 - Data Interface: No
 - Temperature Range: -10°C ~ +60°C
 - Humidity Range: 20-95%
 - Online Update: No
 - Color: Black
 - Size: 160*193*97mm
 - Weight: 220g
 - Certification: CE, FCC ID:N4ZG4P00
-
- 产品型号：FS-G4P
 - 通道个数：4
 - 适配模型：车
 - 无线频率：2.4GHz
 - 发射功率：< 20dBm
 - 无线协议：ANT
 - 遥控距离：> 200m（空旷无干扰地面距离）
 - 通道分辨率：1024级
 - 电池：6V DC 1.5AA*4
 - 充电接口：无
 - 续航时间：依电池类型
 - 低电压报警：< 4.2V
 - 天线类型：内置单天线
 - 数据接口：无
 - 温度范围：-10°C ~ +60°C
 - 湿度范围：20-95%
 - 在线更新：无
 - 遥控器颜色：黑色
 - 外形尺寸：160*193*97mm
 - 机身重量：220g
 - 认证：CE, FCC ID:N4ZG4P00

Receiver overview 接收机概览

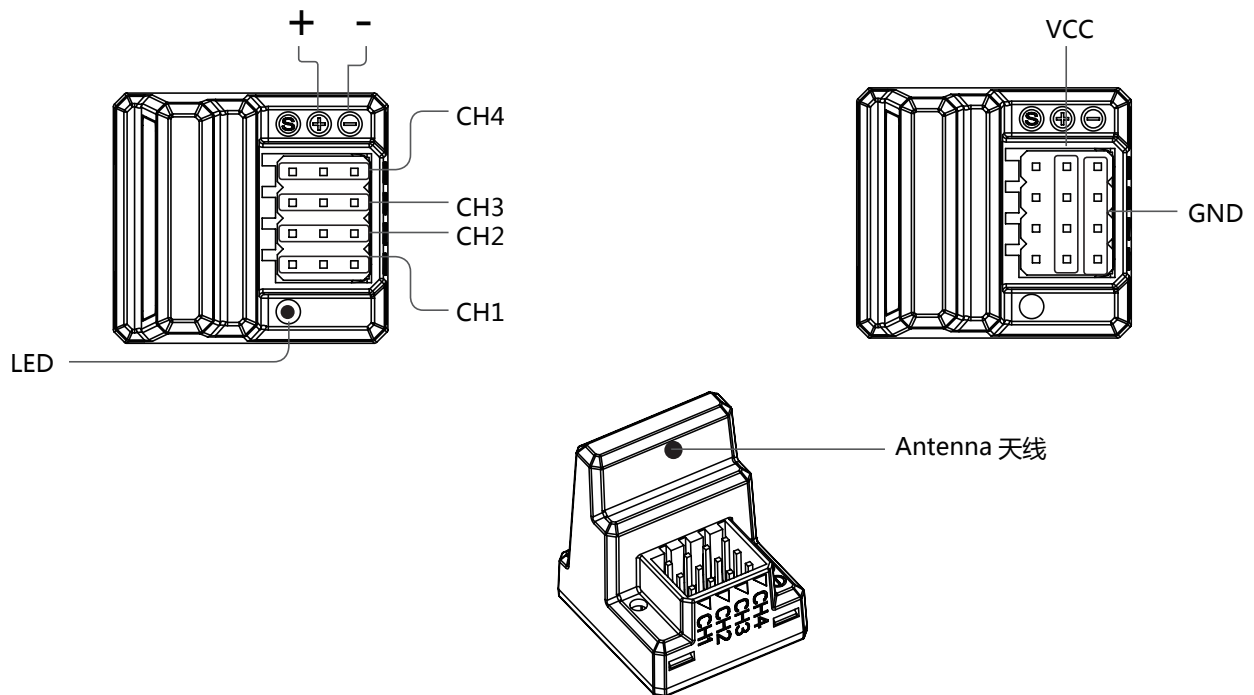

Note
注意

To ensure the best signal quality make sure that the antenna is mounted perpendicular to the model body in an upright position.

为保证信号质量，天线应与模型机身保持垂直，且天线竖立摆放。

Receiver specifications 接收机规格

- Product Mode: FS-R4P
- PWM Channels: 4
- RF: 2.4GHz
- 2.4GHz Protocol: ANT
- Distance: >200m (Ground)
- Antenna Type: Built-in single antenna
- Power supply: 3.5-8.4V
- RSSI: NO
- 产品型号：FS-R4P
- 通道个数：4
- 无线频率：2.4GHz
- 无线协议：ANT
- 遥控距离：> 200m（空旷无干扰地面距离）
- 天线类型：内置单天线
- 电源：3.5-8.4V
- RSSI：无

- Data Interface: PWM
- Temperature Range: -10°C ~ +60°C
- Humidity Range: 20-95%
- Online Update: No
- Size: 22.6*20.6*25.5mm
- Weight: 6g
- Certification: CE, FCC

- 数据接口：PWM
- 温度范围：-10°C ~ +60°C
- 湿度范围：20-95%
- 在线更新：无
- 外形尺寸：22.6*20.6*25.5mm
- 机身重量：6g
- 认证：CE, FCC

Throttle stick position 油门扳机位置



Neutral point
中位

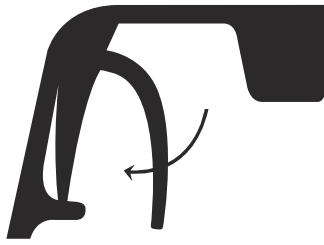

Top point of forward direction
前进方向的顶端

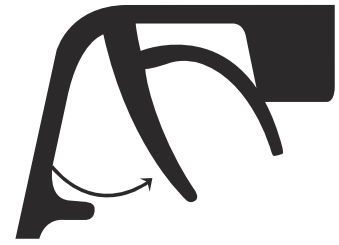

Top point of backward direction
后退方向的顶端

Mode 型号	WP-1040-BRUSHED WP-1040-BRUSHED-Crawler&Boat *	
Cont. / Burst Current 正向、反向持续/峰值电流 (10秒)	Forward: 40A / 180A Backward: 20A / 90A 正向 : 40A / 180A 反向 : 20A / 90A	
Input 支持电压范围	2-3S Lipo, 5-9 Cells NiMH 2-3节锂电 (Lipo) 或 5-9节镍氢 (NiMH) 电池	
Cars Applicable 主要适用车型	1:10 on-road, off-road Buggy, Truggy, SCT 1:10 Crawler, Tank & Boat 普通版: 1/10 电房、电越、短卡、大脚、卡车 攀爬/船用版: 1/10 攀爬车、坦克及各种模型船	
Motor Limit 支持电机T数	2S Lipo or 5-6 cells NiMH 2节锂电或5或6节镍氢	540 or 550 size motor $\geq 12T$ or RPM < 30000 @7.2V 540或550尺寸电机 $\geq 12T$ 或RPM低于30000 @7.2V
	3S Lipo or 7-9 cells NiMH 3节锂电或7或9节镍氢	540 or 550 size motor $\geq 18T$ or RPM < 20000 @7.2V 540或550尺寸电机 $\geq 18T$ 或RPM低于 20000 @7.2V
Resistance 内阻 (单桥臂)	Fwd: 0.002 Ohm, Bwd: 0.004 Ohm 正转0.002欧姆, 反转0.004 欧姆	
Built-in BEC BEC输出	2A/6V (Linear mode BEC) 6V/2A (线性稳压BEC)	
Dimension&Weigh 尺寸和重量	WP-1040-BRUSHED: 46.5*34*28.5, 70g WP-1040-BRUSHED-CRAWLER: 46.5*34*28.5, 70g	

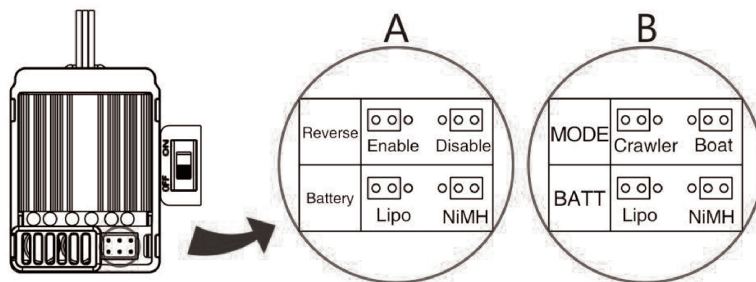

A:WP-1040-BRUSHED

B:WP-1040-BRUSHED-CRAWLER & BOAT

Trouble 故障现象	Possible Reason 可能原因	Solution 解决方法
<p>After power on, motor can't work, no sound is emitted, and LED is off.</p> <p>上电后指示灯不亮,不自检,无鸣音。</p>	<p>1.The ESC doesn't get its working voltage; Connections between battery pack and ESC are broken. 2.Switch is damaged.</p> <p>1. 电调没有得到工作电源。 2. 电调开关损坏。</p>	<p>1.Check the battery wires connection or replace the defective connectors. 2.Replace the switch.</p> <p>1. 检查电池到电调的电源输入通路是否有焊接不良情况,并重新焊好。 2. 更换电调开关。</p>
<p>After power on, motor can't work; red LED blinks.</p> <p>上电后红色LED 闪烁,电机无法启动。</p>	<p>1.Throttle signal is abnormal. 2.Automatic throttle range calibration is failed.</p> <p>1. 电调油门线插反或通道插错。 2. 电调无法完成油门自检校调。</p>	<p>1.Check the throttle wire connection; make sure it is plugged into the throttle channel of the receiver. 2.Set the "TRIM" of throttle channel to 0 or turn the knob to its neutral position.</p> <p>1. 将电调的油门排线按正确方向插到接收机的油门通道 (Throttle, 通常为CH2)。 2. 将遥控器的油门通道的中点微调 "TRIM" 调为0 或相应旋钮调到中点位置。</p>
<p>The car runs backward while giving throttle. (The motor runs in the opposite direction.) 遥控器做前进操作,车子反而倒退。</p>	<p>The wire connections between ESC and the motor need to be changed.</p> <p>遥控器油门通道方向设置错误或马达接线错误。</p>	<p>Swap two wire connections between the ESC and the motor.</p> <p>交换 ESC 和电机之间的两个电线连接。</p>
<p>The car can't reach full speed, the accelerator is maxed out,the red light is not always on.</p> <p>车子无法达到全速,油门打到最大,红灯不恒亮。</p>	<p>The direction of throttle channel is not correct.</p> <p>遥控器设置错误。</p>	<p>Check the settings. Set D/R, EPA, ATL to 100% or turn the knobs to maximum value. Set TRIM to 0 or turn the knob to its neutral position.</p> <p>1. 将遥控器油门通道的 "D/R"、"EPA"、"ATL" 等参数调到100%或相应旋钮调到最大位置,油门通道的中点微调 "TRIM" 调为0 或相应旋钮调到中点位置。</p>
<p>The car can't go backward.</p> <p>车子无法倒车。</p>	<p>1.The jumper position is wrong. 2.The neutral point of throttle channel is changed or drifted.</p> <p>1. 倒车选项跳线帽位置错误。 2. 油门中点偏移。</p>	<p>1.Check the jumper and plug it to the correct position. 2.Set the "TRIM" of throttle channel to 0 or turn the knob to its neutral position.</p> <p>1. 将倒车选项跳线帽插入正确位置。 2. 将遥控器的油门通道的中点微调 "TRIM" 调为0 或相应旋钮调到中点位置。</p>
<p>The car can't go forward, but can go backward.</p> <p>车子正向加油不走,反向倒车却行走。</p>	<p>The direction of throttle channel is not correct.</p> <p>遥控器油门通道方向设置错误。</p>	<p>Reset the direction of throttle channel from original "NOR" to "REV", or from original "REV" to "NOR". 将遥控器油门通道反向换,从原 "NOR" 换为 "REV" 或从原 "REV" 换为 "NOR"。</p>
<p>The motor suddenly stops running while in working state.</p> <p>电机转动过程中,突然停转。</p>	<p>1.The throttle signal is lost. 2.Low voltage cut-off protection or Over-heat cut-off protection has been activated.</p> <p>1. 油门信号丢失。 2. 电调进入电池低压保护或过热保护状态。</p>	<p>1.Check the transmitter and the receiver. 2.Replace the battery pack, or cool down the ESC.</p> <p>1. 检查遥控器电池电压是否过低。 2. 电调红灯闪烁表示低压或过热保护,请更换电池组或检查电调温度。</p>

Instructions 遥控产品规格

Trouble 故障现象	Possible Reason 可能原因	Solution 解决方法
The car cannot get top speed and the red LED doesn't solid on at full throttle 车子无法前进也无法倒车，指示灯正常。	Some setting in the transmitter are incorrect. 遥控器油门通道方向设置错误。	1.Check the connections and replace the defective connectors. 2.Replace the motor. 1. 检查马达和电调之间的接头，确保连接可靠。2. 更换新马达。
Motor is cogging when accelerated quickly. 电机启动时急加速，电机有卡住或停顿的现象。	1.The battery has limited discharge ability. 2.Motor RPM is too high, the gear ratio is too aggressive. 3.Something wrong in the driving system of the car. 1. 电池放电能力不够。2. 电机转速过高，齿轮比搭配过于激进。3. 车子传动系统有问题。	1.Use battery with better discharge ability. 2.Use motor with lower RPM, or use smaller pinion to get softer gear ratio. 3.Check the driving system of the car. 1. 更换放电能力强的电池。2. 更换低速电机，或将减速比提高。3. 检查车架传动系统是否顺畅。

VEHICLE SETUP 车辆设置

Operating the vehicle 车辆操作

- Step 1: turn on the transmitter, the headlamp of the transmitter will flash and enter search mode.
Step 2: turn on the receiver switch, the front lights of the vehicle will flash and enter search mode.
Step 3: when the transmitter and receiver are successful connected, the headlamp of the transmitter will be on for a long time, and the front lights of the vehicle will be on for a long time.

- 步骤1：打开发射器，发射器前灯会闪亮，进入搜索模式。
步骤2：打开接收器开关，车前灯会闪亮，进入搜索模式。
步骤3：当发射器，接收器对上频成功时，发射器前灯会长亮，车前灯会长亮。

Battery Precautions 电池注意事项

- Never charge a lithium polymer battery with a charger designed for Nicd, NIMH, or any other type of battery chemistry.
- Use ONLY charger designed for LiPo battery.
- Do not leave LiPo battery unattended during charging.
- Do not overcharge the battery.
- Always charge LiPo batteries on non-flammable, heat-resistant surfaces.
- Always use a LiPo-safe bag or container while charging.
- Do not allow LiPo cells to overheat at any time. Cells which reach greater than 140 Fahrenheit(60℃) will usually become damaged and will catch fire.
- Do not charge the LiPo pack while it is still in the model.
- Never charge or store battery packs in a vehicle.
- Do not discharge LiPo, doing so will damage the battery.
- Do not expose LiPo cell to water or moisture at any time.
- Do not store battery near open flame or heater.
- Do not assemble LiPo cells or pre-assembled packs together with other LiPo cells or packs.
- Always store LiPo battery in a secure location away from children.
- Always remove the LiPo battery if model is involved in any kind of crash.
- Carefully inspect the battery and connectors for even the smallest damage.
- CAUTION: Cells may become hot after usage.

- Allow the pack to cool to room temperature prior to recharging.
- Do not allow the electrolyte to get into eyes or on skin. Wash affected areas immediately if they come into contact with electrolyte.
- Do not alter or modify connectors or wires of a LiPo battery pack.
- Always inspect the condition of the battery before charging and operating.
- Do not short circuit the LiPo battery.
- Do not have contact with a leaky/damaged battery directly.
- Do not charge battery out of recommended temperature range(0°C-45°C)
- 不要使用NiCd、NIMH或任何其他类型的充电器给LIPO锂聚合物电池充电。
- 请使用LIPO锂聚合物的专用充电器给LIPO锂聚合物电池充电。
- 请勿在无人看管的情况下充电。
- 电池请勿过充。
- 请勿将电池放置在易燃、不耐热的表面上充电。
- 总是使用安全袋或安全容器给电池充电。
- 保证电池在任何时候都不过热。电池温度超过140华氏度（60°C）则易造成损坏，甚至引发火灾。
- 请勿将电池长期置于模型产品内，更勿在模型产品内直接充电。
- 请勿给电池放电，以免损坏电池。
- 任何时候请勿将电池暴露在水或湿气之中。
- 请勿在明火或加热器附近储放电池。
- 请勿与其他未组装或预组装的电池混用。
- 需将电池存放在远离儿童的安全位置。
- 模型如出现任何碰撞，需立刻拆除电池。即使出现微小的损坏,也需仔细检查电池和连接器。
- 注意：使用后电池可能会发热，需让电池冷却到室温后再进行充电。
- 请勿让电解液接触眼睛或皮肤。如电解液不慎接触到身体的任何部位，请立即进行清洗。
- 请勿替换或修改电池组的连接器或电线。
- 在进行充电或其他任何操作之前需检查电池的状况。
- 请勿造成电池短路。
- 请勿直接接触已泄漏或已损坏的电池。
- 请勿超出建议温度范围充电电池（0度-45度）。

Connecting the battery 连接电池

Step 1: Release the buckles to separate the car shell from chassis.

Step 2: Place the battery in the battery compartment on the frame and fix it with the attached rubber band.

Step 3: Connect the battery plug to the receiver/ESC (2-in-1) unit.

Step 4: Lock the buckles to fix the car shell.

步骤1：松开卡扣，如图分离车壳与车架。

步骤2：将电池放置在图示电池舱位，使用所附橡胶轧带固定。

步骤3：连接电池插头至接收机

步骤4：锁紧卡扣固定车壳。



Note
注意

1. If it is not in use for a long time, unplug and take off the battery to prevent battery leakage.
 2. Do not open, disassemble, or attempt to repair the battery.
 3. The battery needs to be disconnected from vehicle before it can be charged
 4. Do not charge battery in vehicle.
- 1、如果长时间不用，请拔下电池，以防电池损坏。
 - 2、不要打开、拆解或试图维修电池。
 - 3、在给电池充电之前，需要先断开电池与车辆的连接。
 - 4、请勿在车内给电池充电。

VEHICLE SETUP 车辆设置

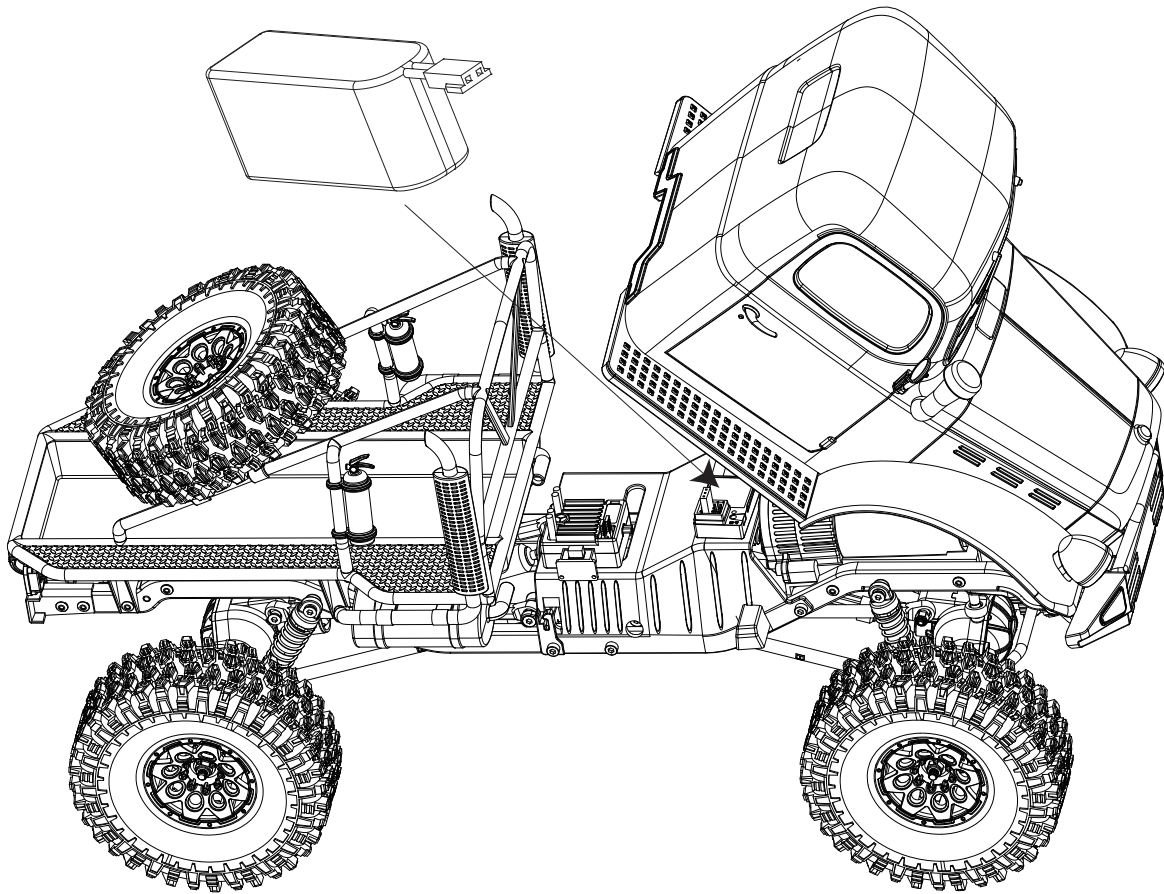

Decal Application 贴纸应用

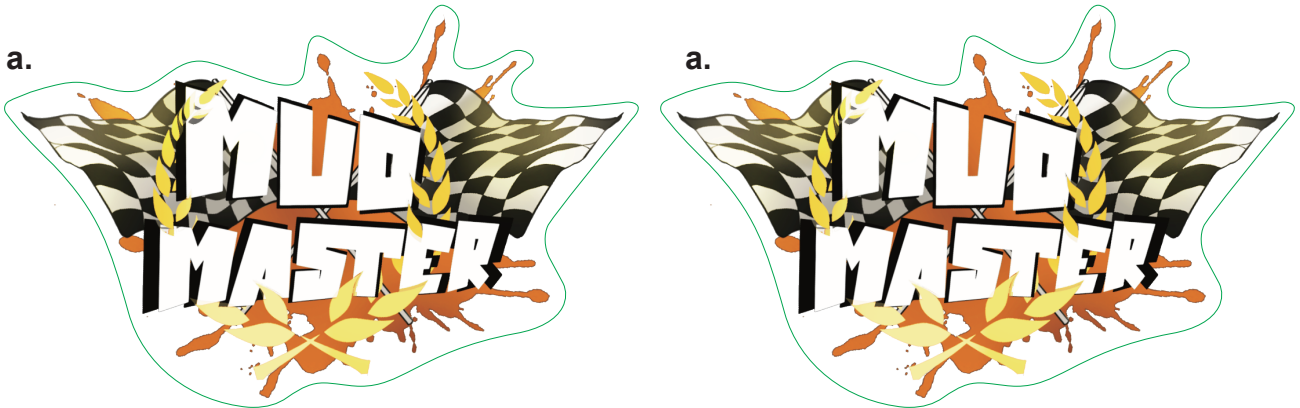

b. **ATLAS 4X4**

b. **ATLAS 4X4**

d. *California*
5HLC563

d. WESTERN AUSTRALIA
KANGAS 70

d. **532-HZC**
QUEENSLAND-SUNSHINE STATE

d. TEXAS
032-KKL
THE LONE STAR STATE

d. TREASURE STATE
6-88015A
MONTANA - 10

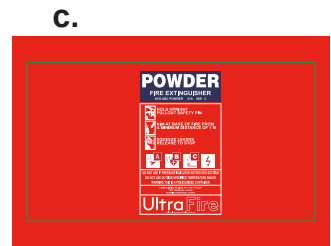
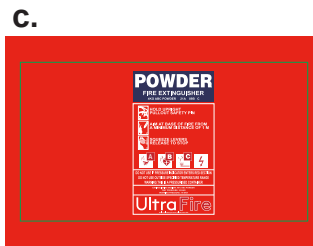

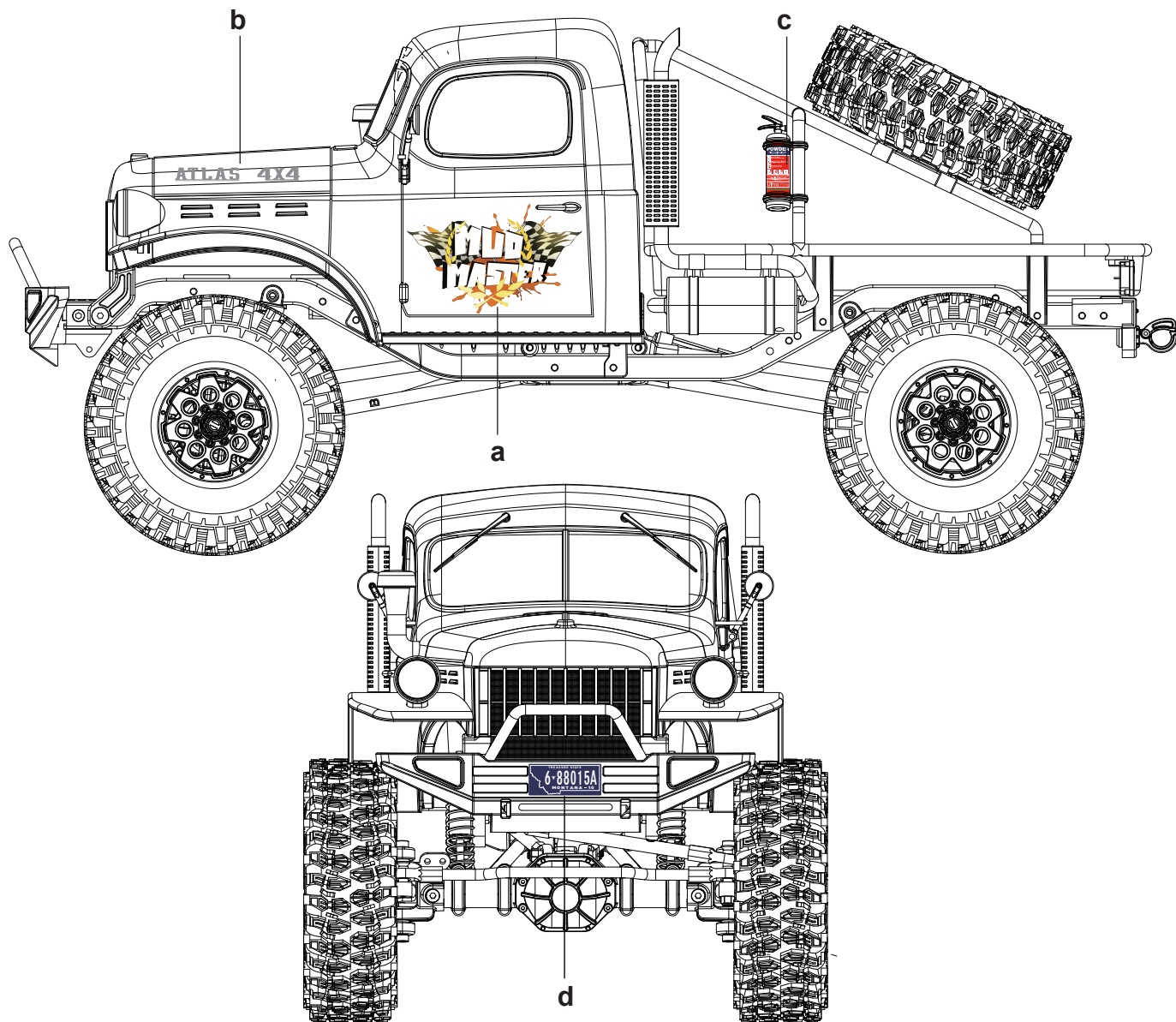

Spare parts list 配件列表

C1573	Transmission gear box assembly	中传动牙箱品成	C1568	Footboard	踏板
C1393	Climbing wheels	攀爬车轮	C1569	Hopper	车斗
C1545	Front axle assembly	前桥成品	C1570	Anti-roll bar	防滚架
C1546	Front axle plastic parts	前桥胶件	C1571	Fire extinguisher	灭火筒
C1547	Oil shock absorbers assembly(2pcs)	避震器总成(一对)	C1572	Car decal sheet	车身装饰贴纸
C1548	Rear axle assembly	后桥成品	C1009	Ball cap for linkage & rod	连杆波帽
C1549	Rear axle plastic parts	后桥胶件	C1010	Transmission shaft assembly	传动轴品成
C1550	Front bumper set	前防撞	C1011	Main gear box set	驱动牙箱组散件
C1551	Rear bumper set	后防撞	C1016	Steering C hub parts	转向C座件
C1552	Mirror set	高清镜	C1020	Screw nut set	螺母包
C1553	Lens set	灯片	C1021	Wheel hex set	车轮6角件
C1554	Spare tire rack	备胎架	C1022	Pin lock set	销针

Spare parts list

配件列表

C1421	Slipper spring	限滑器弹簧	C1023	Bearing set	轴承包
C1422	Slipper pad	限滑片	C1056	Waterproof 15kg metal gear servo	防水15kg金属齿舵机
C1423	Spur gear 42T 0.6	大齿42T 0.6	C1077	Drive cup set	驱动杯套装
C1424	5.8 ball head	5.8波头	C1082	Front outdrive shaft assembly	前轮传动总成
C1425	Gear set	齿轮套装	C1080	35T brushed 550 motor	35T有刷550电机
C1555	Led light wire set	灯线	C1081	Gasket set	垫圈
C1556	11036YL car body assembly	黄色车壳成品	C1084	Bushing set	套筒介子
C1557	11036OR car body assembly	橙色车壳成品	C1097	Pinion gear	马达齿
C1558	11036BU car body	蓝色车壳	C1100	Rear wheel shaft	后轮轴
C1559	Clear body	透明车壳	C1105	2.4GHz transmitter	2.4GHz发射器
C1560	Light cup	灯杯	C1106	2.4GHz transmitter & receiver set	2.4GHz发射器+接收器
C1561	Screw set	螺丝包	C1399	Steering link	转向连杆
C1562	Exhaust pipe	排气管	C1578	Waterproof 40A brushed esc	防水40A电调
C1563	Esc mount	电调座	C1579	2.4GHz receiver set	2.4GHz接收器
C1564	Metal plate	仿真钢板	C1085	Aluminium steering bracket set	金属转向支架
C1565	Rearview mirror and snorkel	后视镜及涉水喉	C1083	Aluminium steering C hub parts	金属转向C座件
C1566	Handel set and wiper	门把手及雨刷	C1101	Metal transmission shaft	五金传动轴成品
C1567	Grille	水箱			

Spare tire installation 备胎组安装

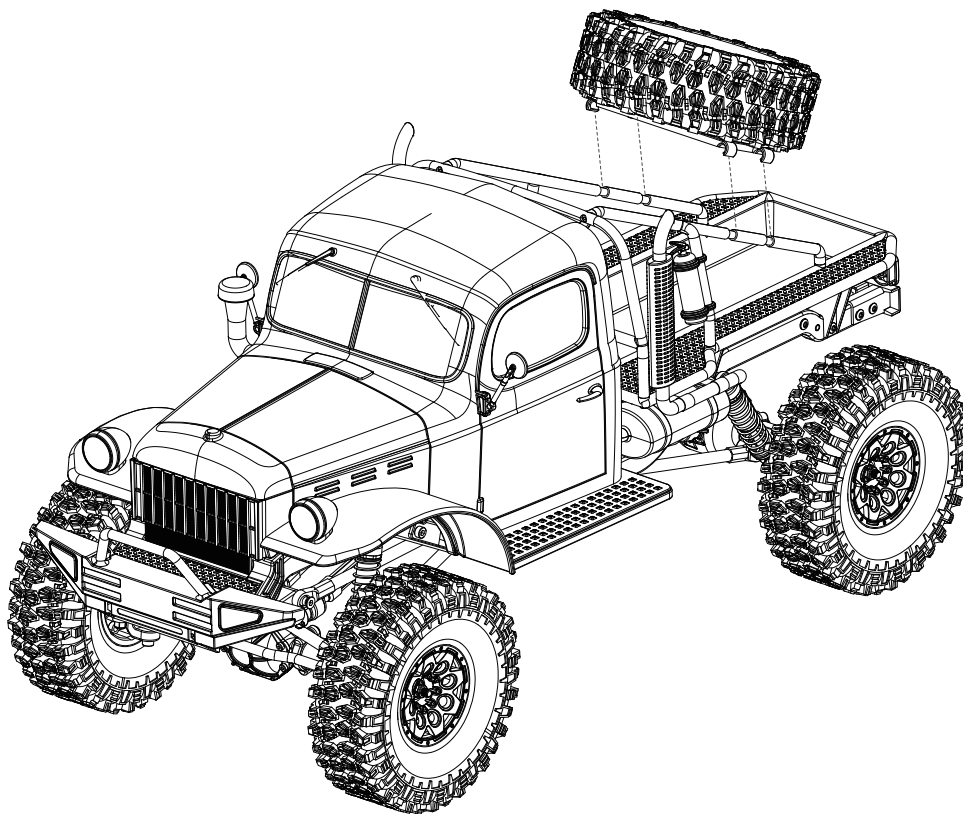

Lock the assembled spare tire onto the left and right bracket of the roll cage as shown.

如图所示，将备胎组安装至防滚架左右两侧支架上。

EN:Front Oil Shock Absorbers Assembly

CN:前避震

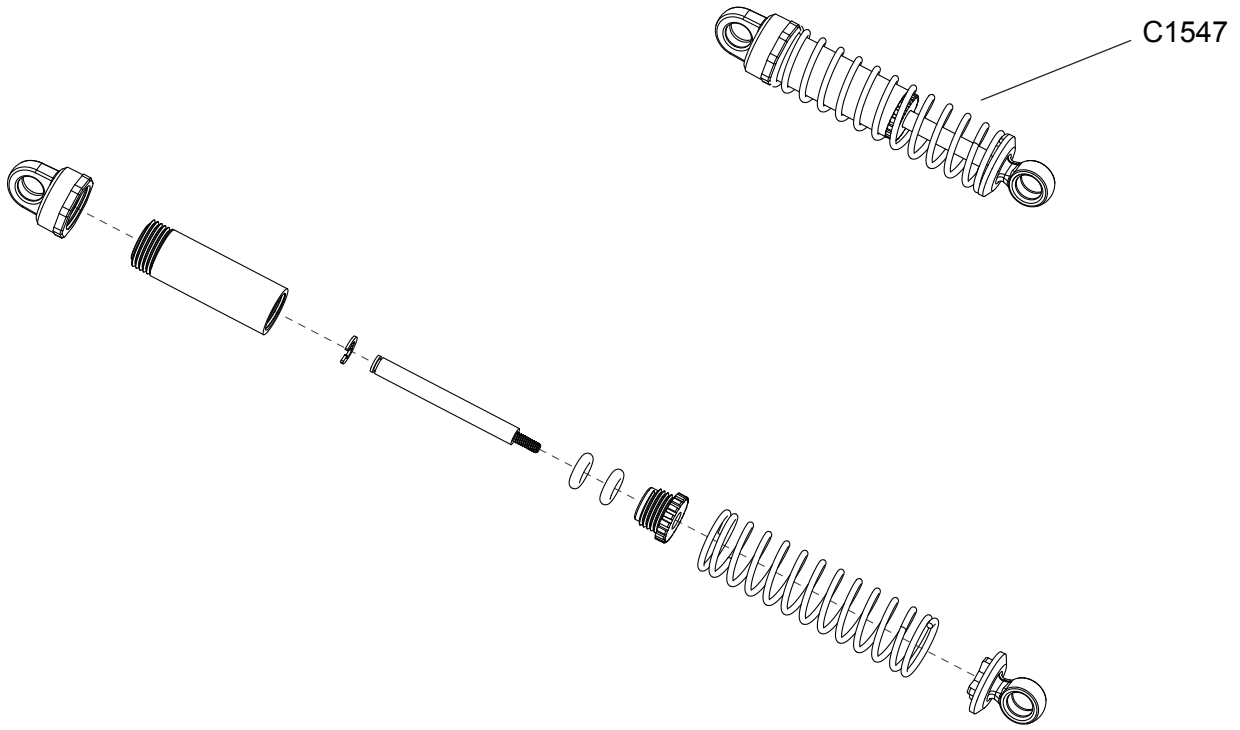

EN:Rear Oil Shock Absorbers Assembly

CN:后避震

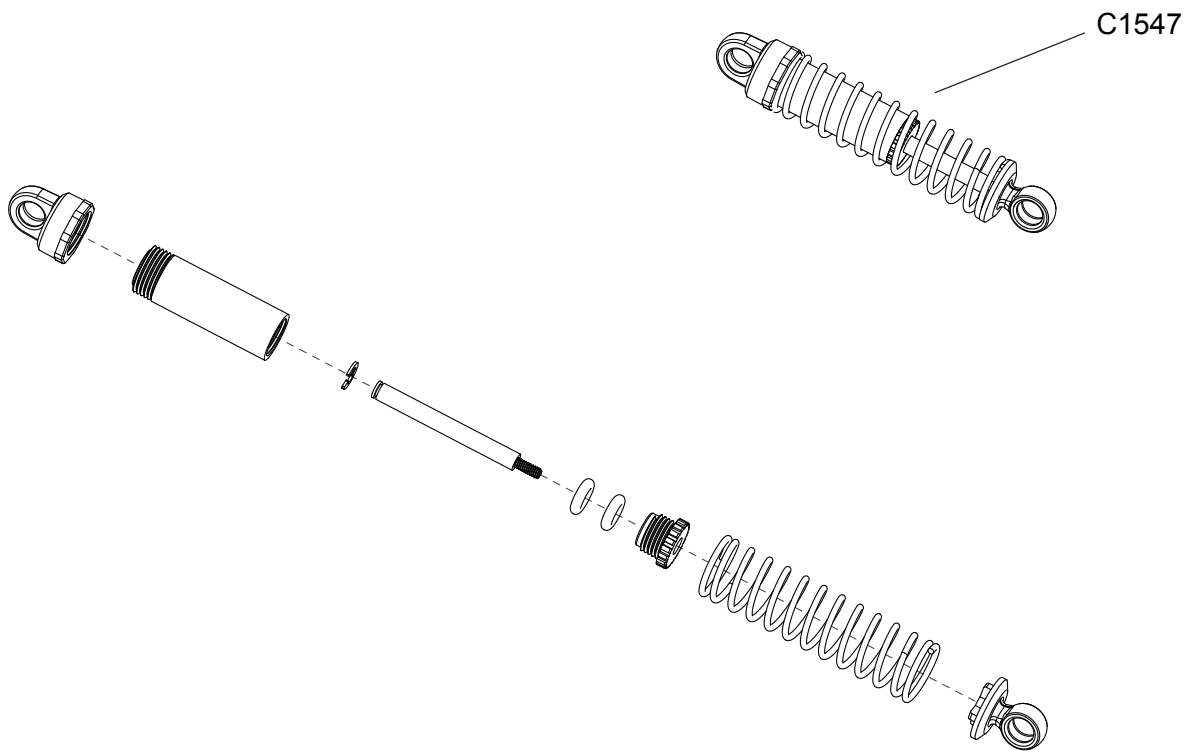

EN:Semi-finished Chassis Set A CN:车架半成品A

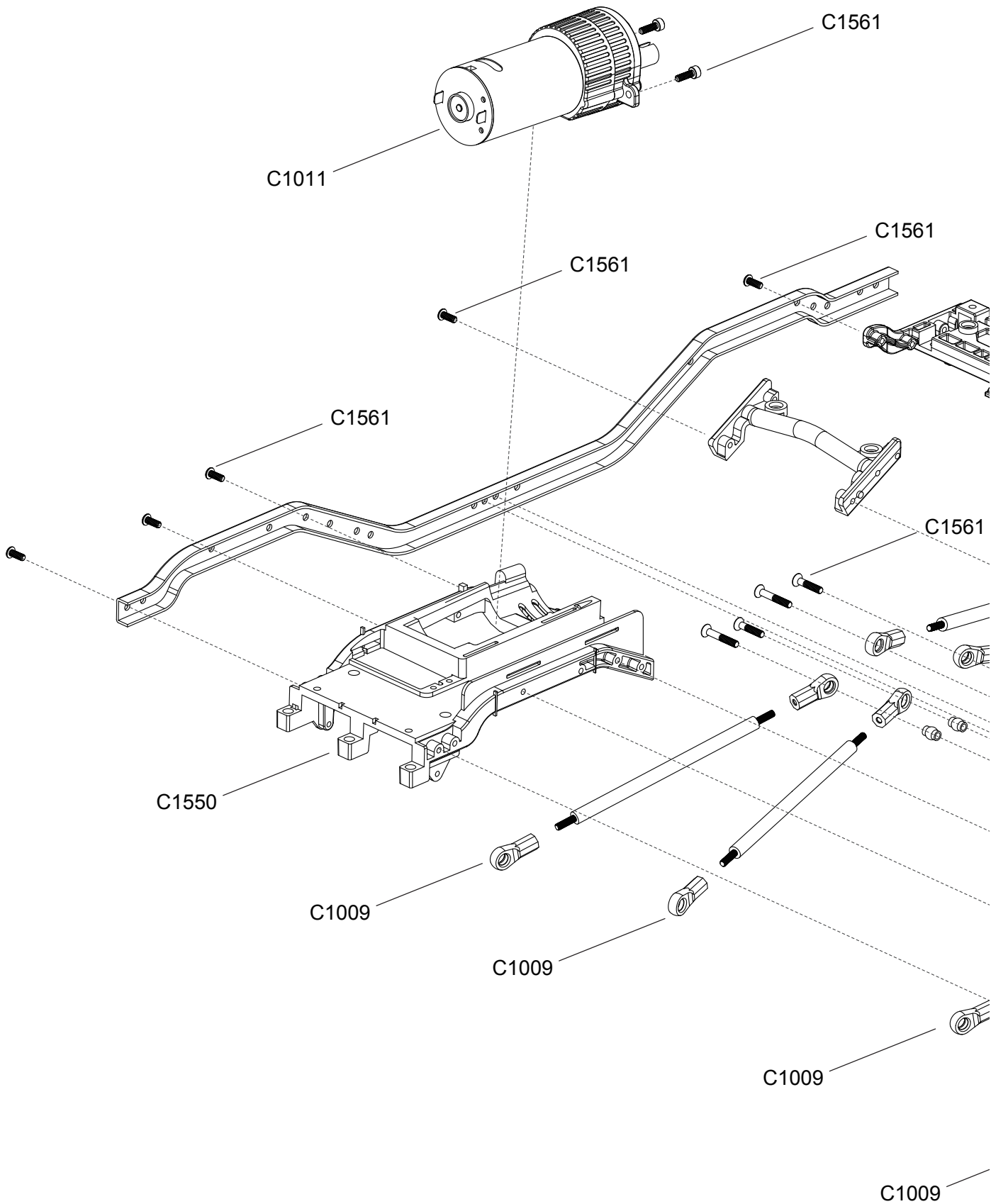

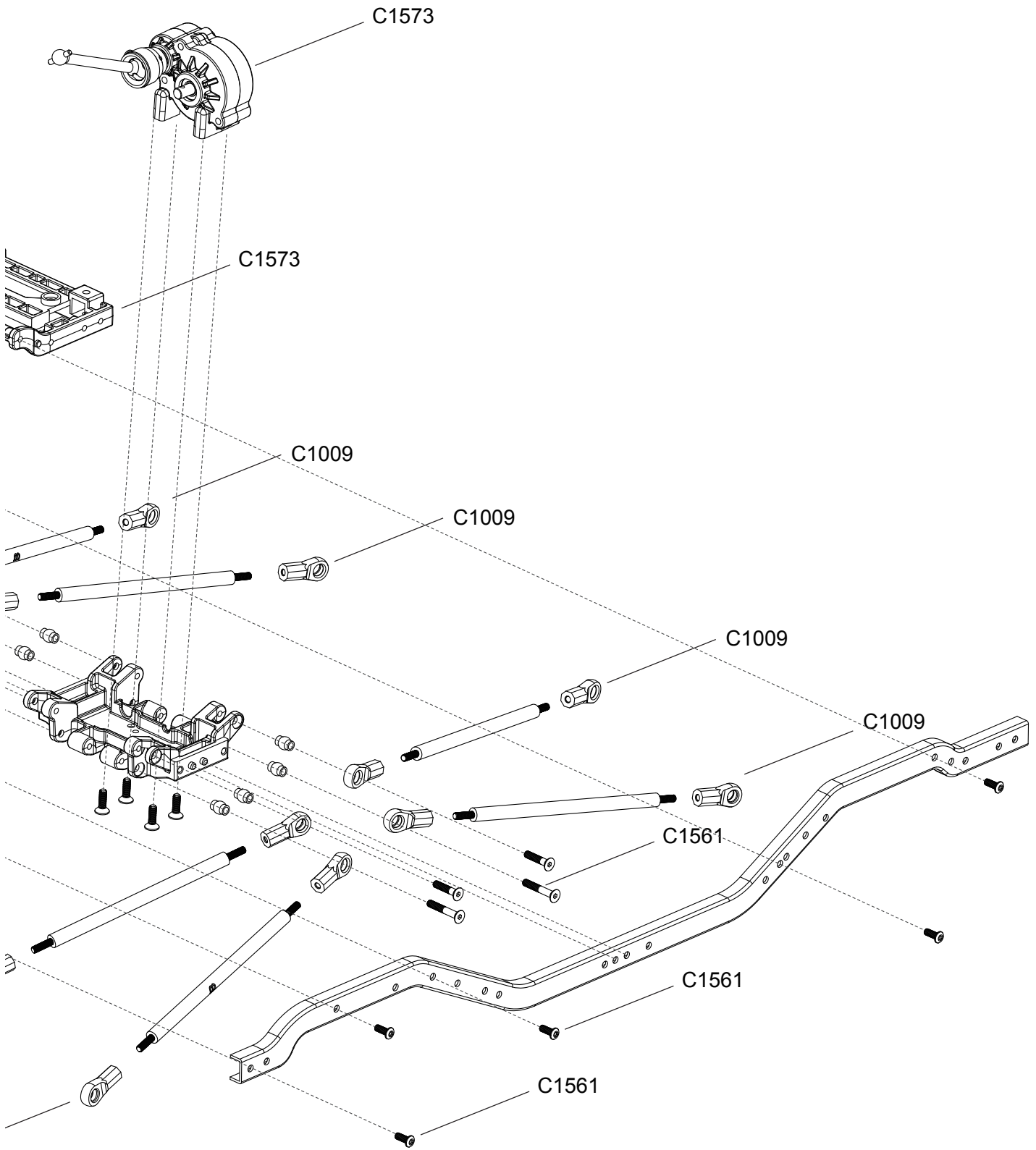

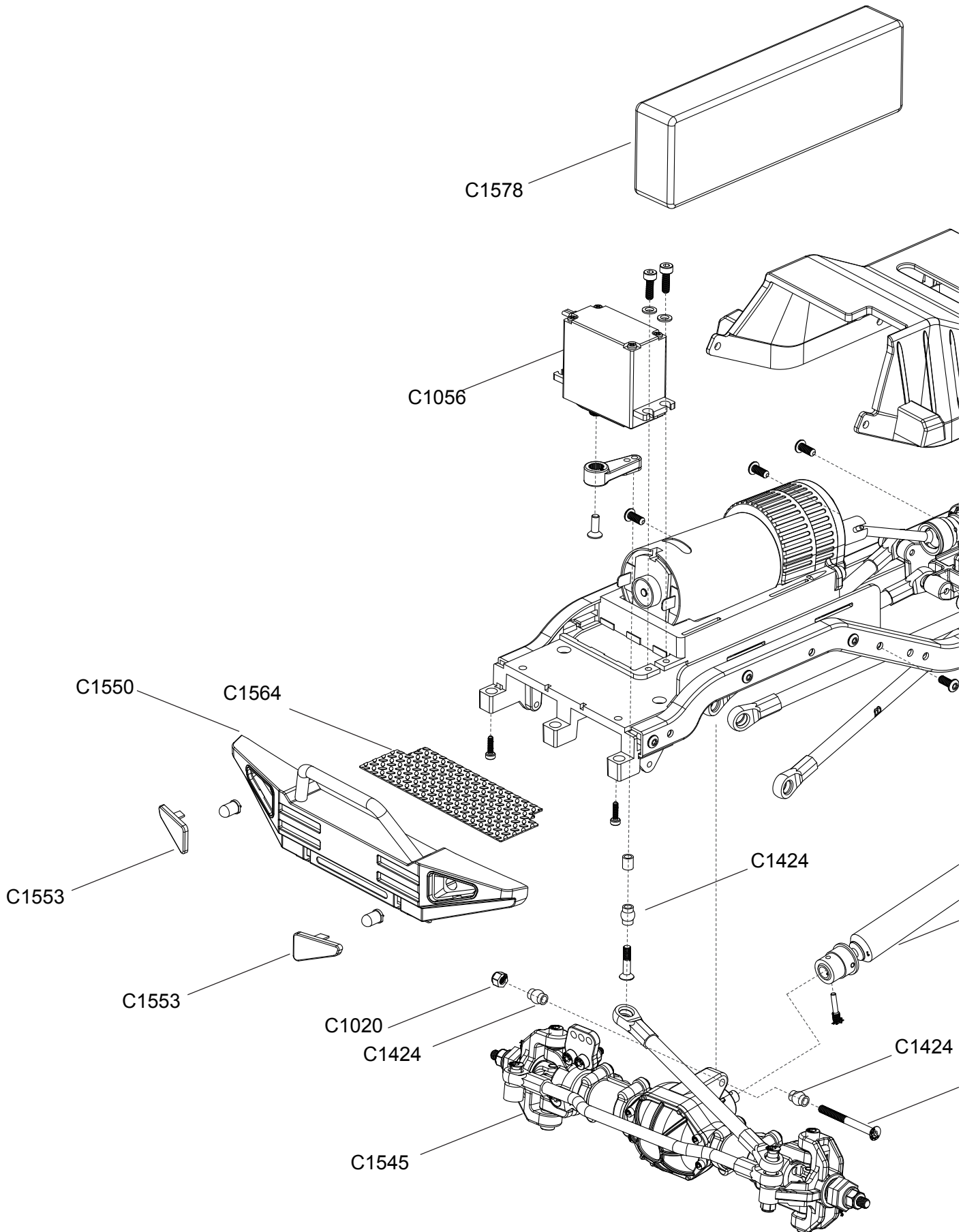

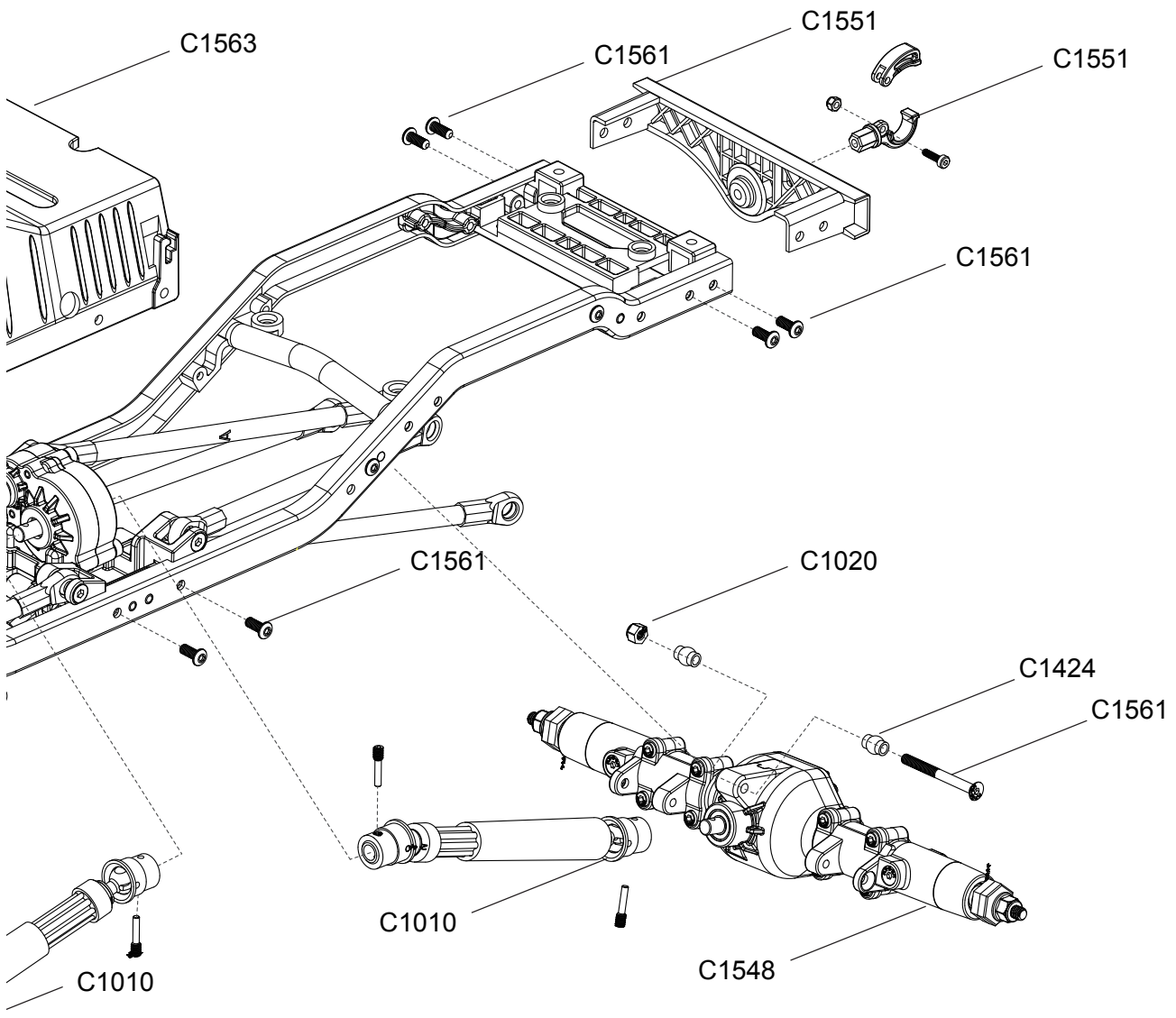

C1561

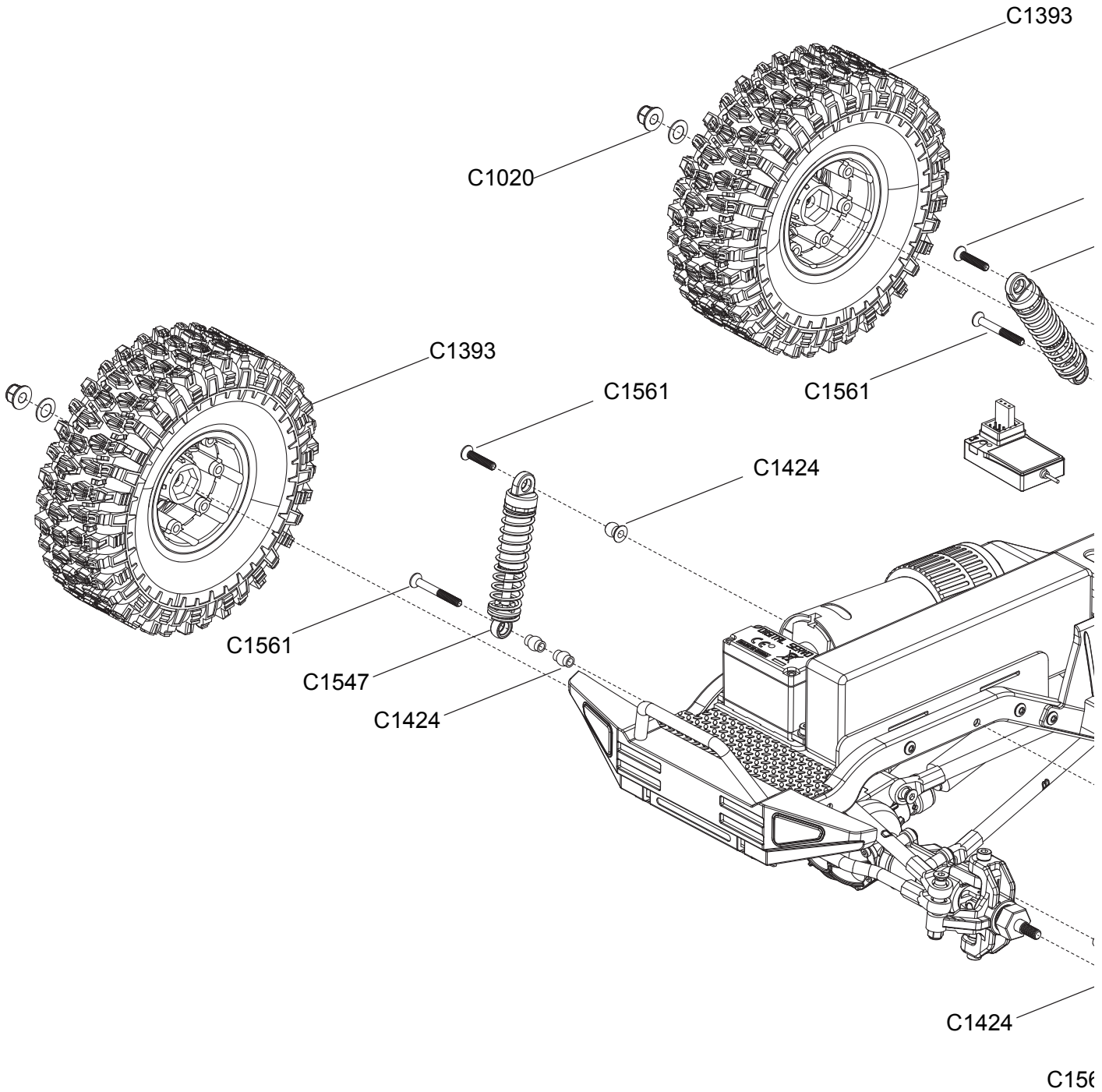

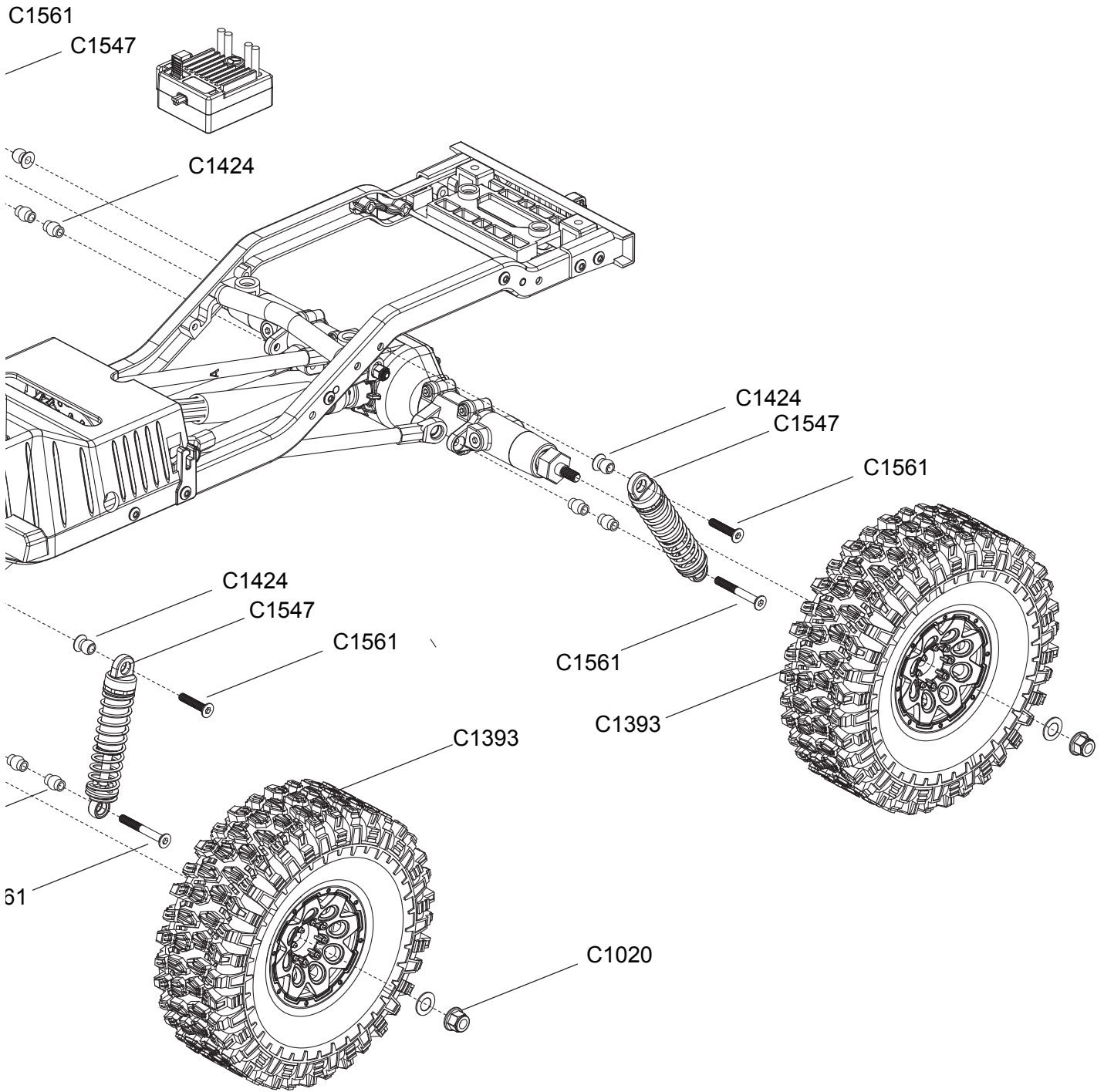

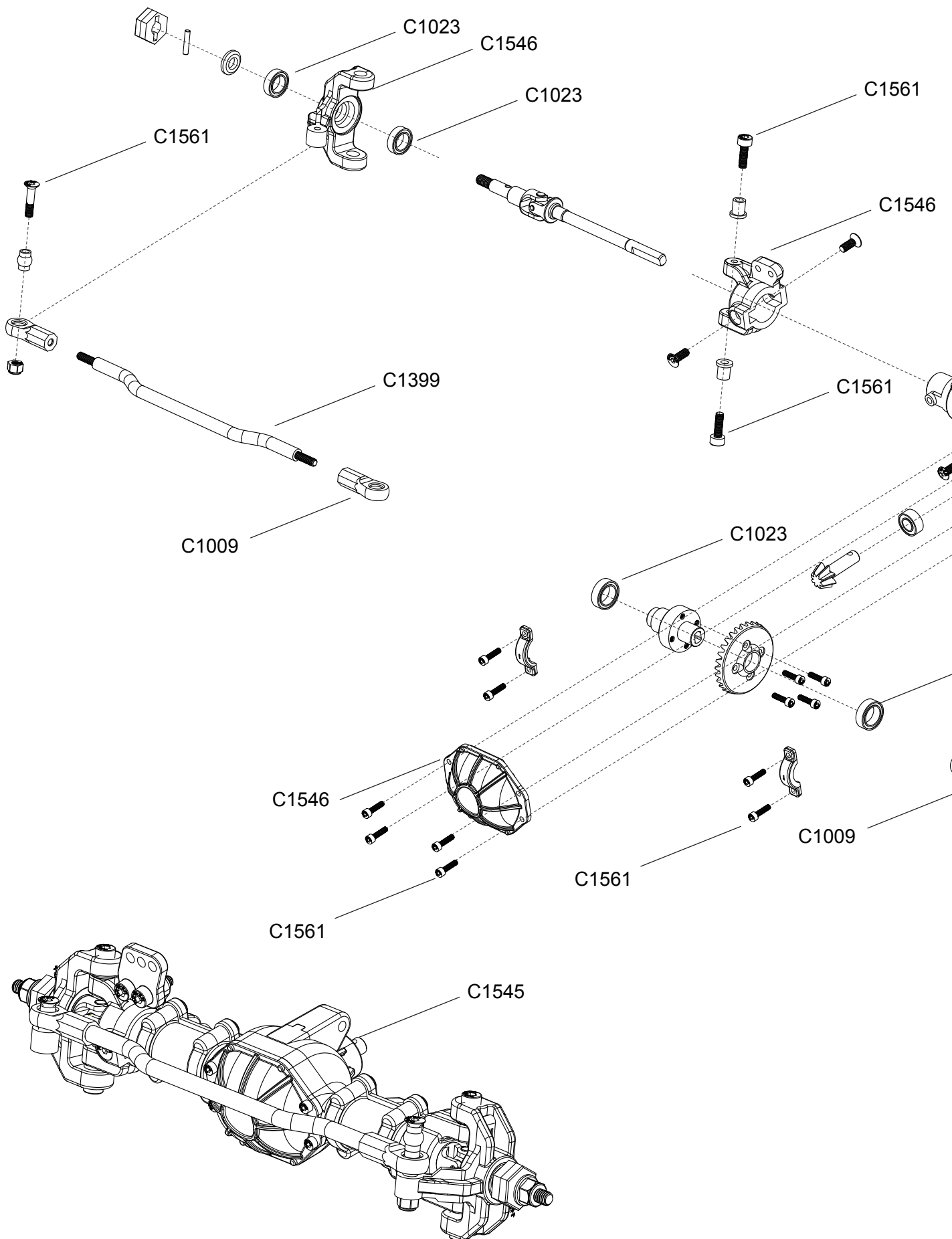

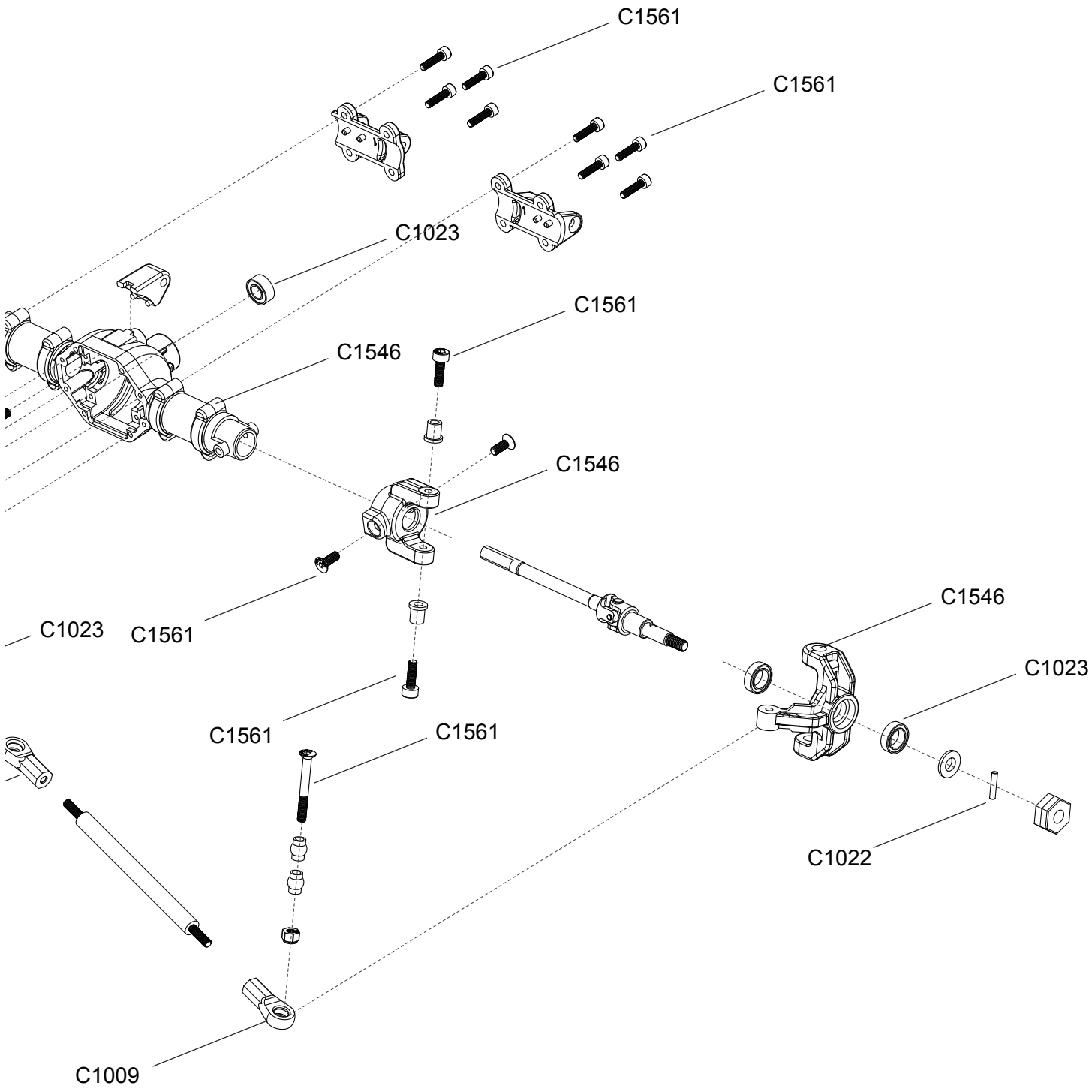

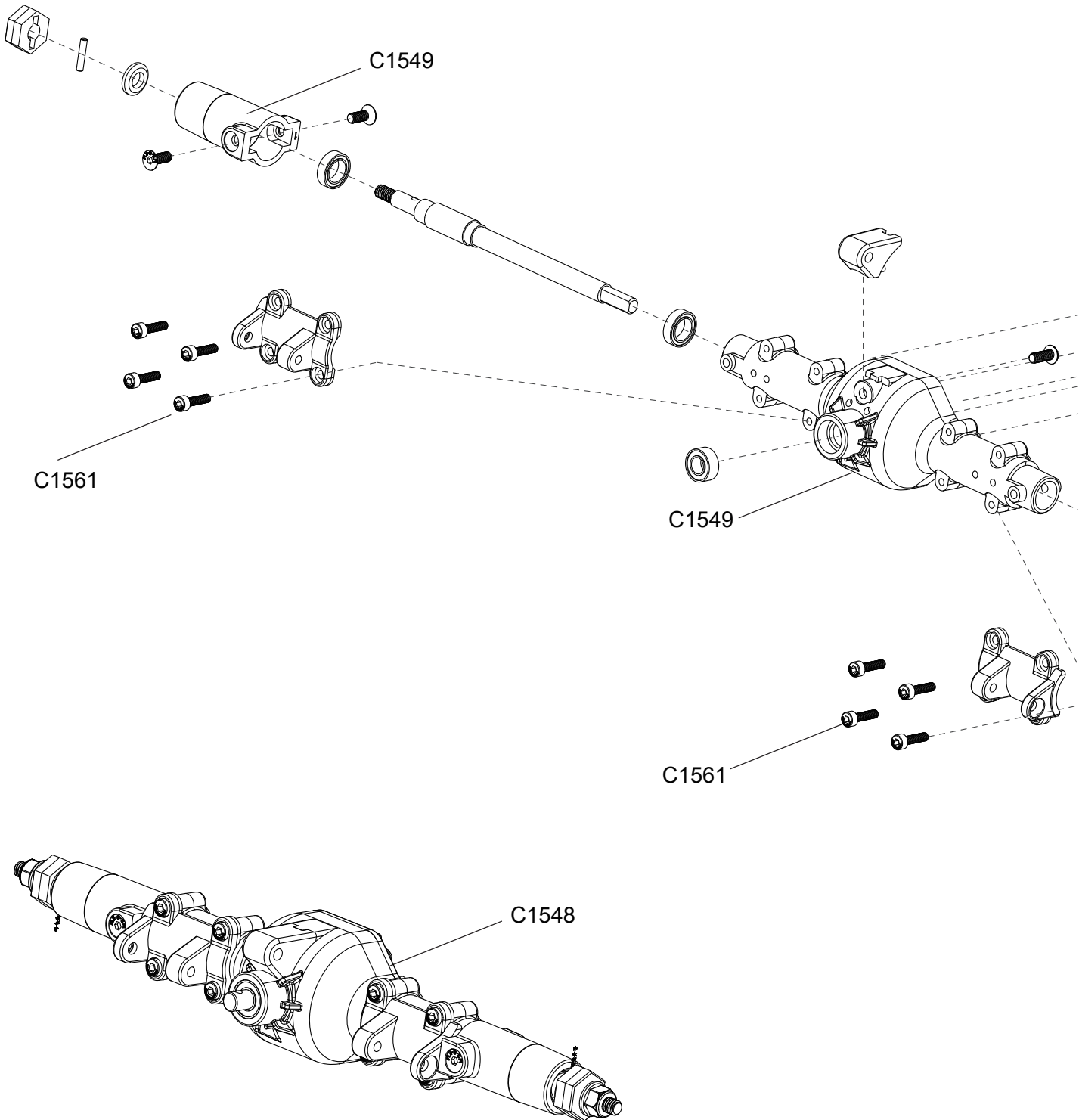

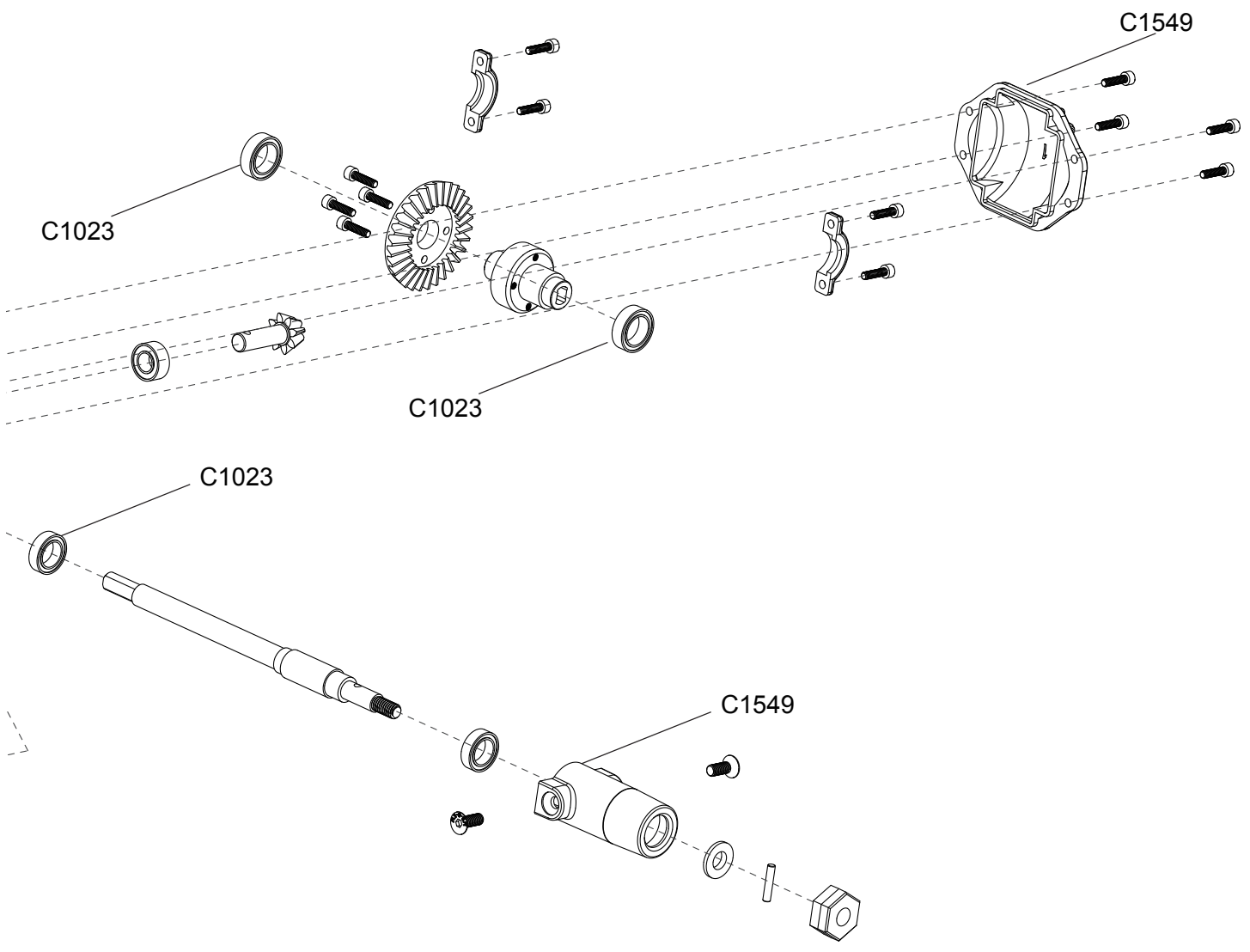

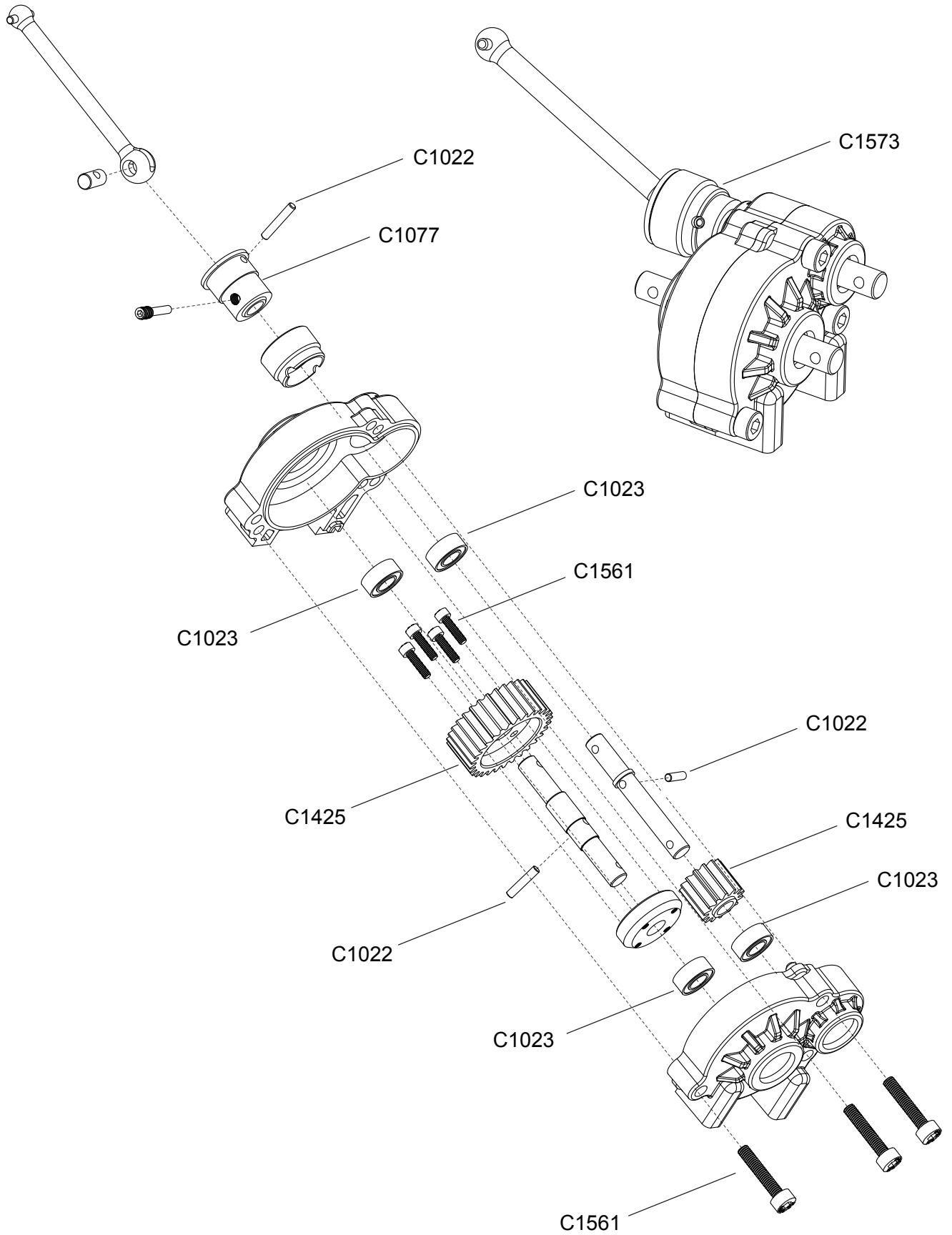

EN:Transmission Shaft Assembly

CN:传动轴组

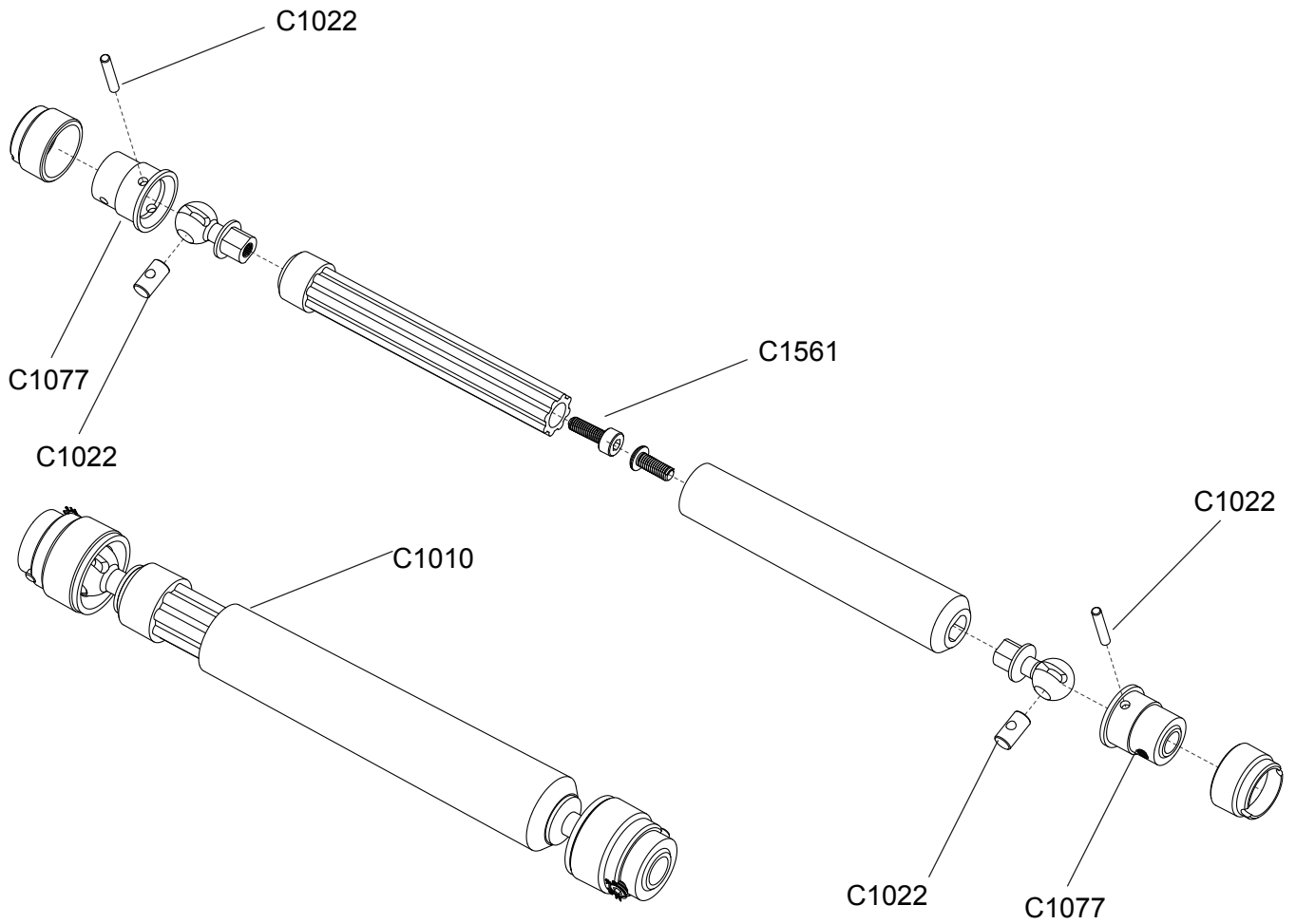

EN:Main Gear Box Set

CN:驱动牙箱组

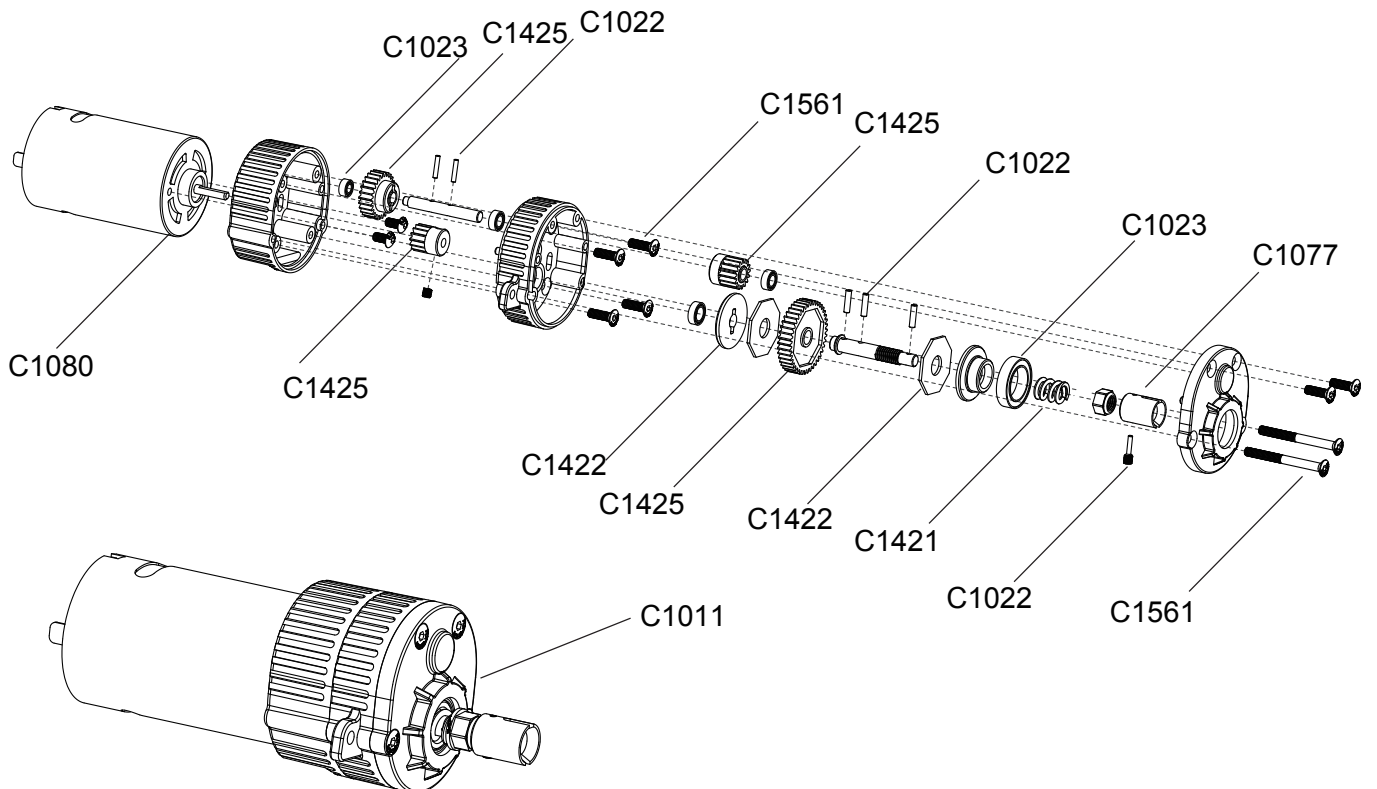

EN:Left Exhaust Pipe

CN:左排气管组

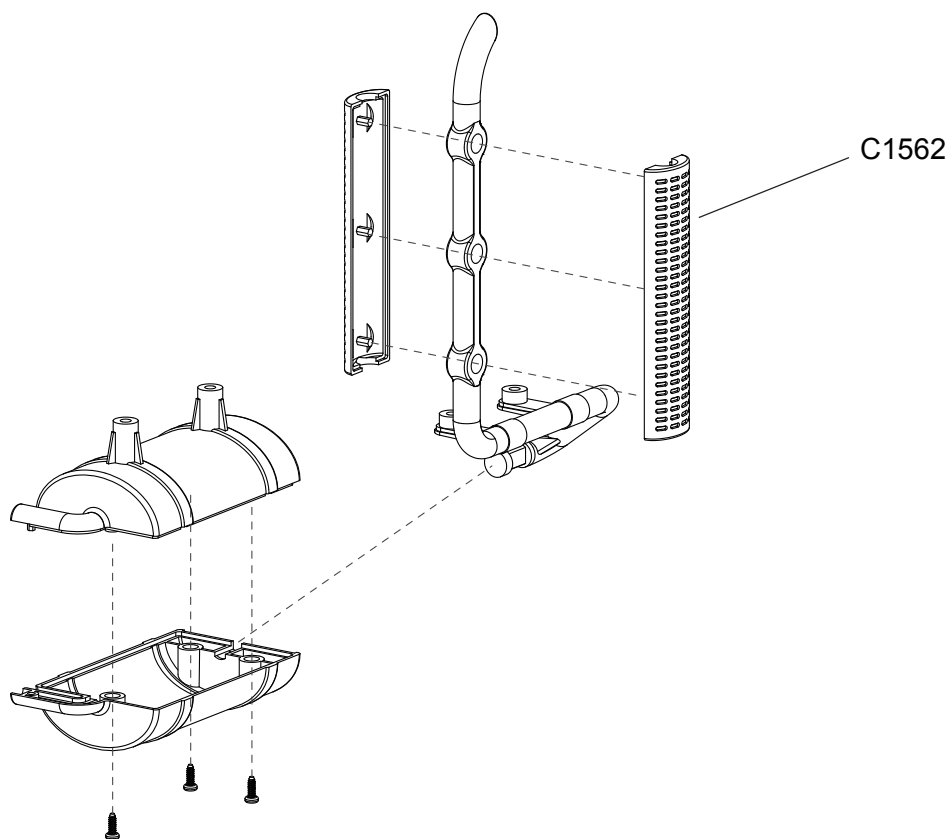

EN:Right Exhaust Pipe

CN:右排气管组

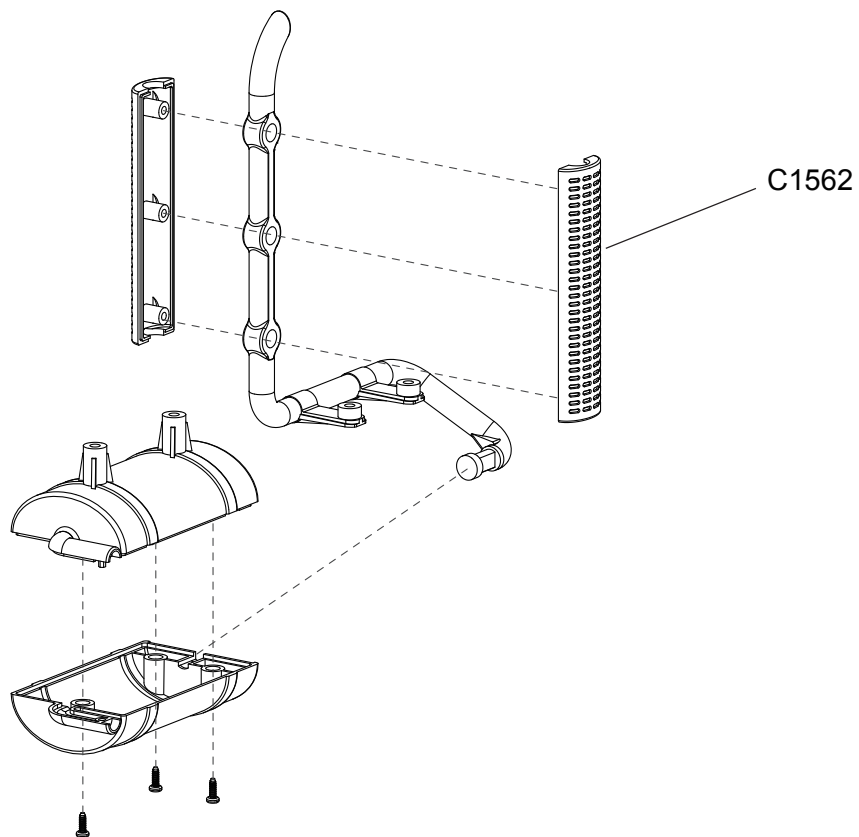

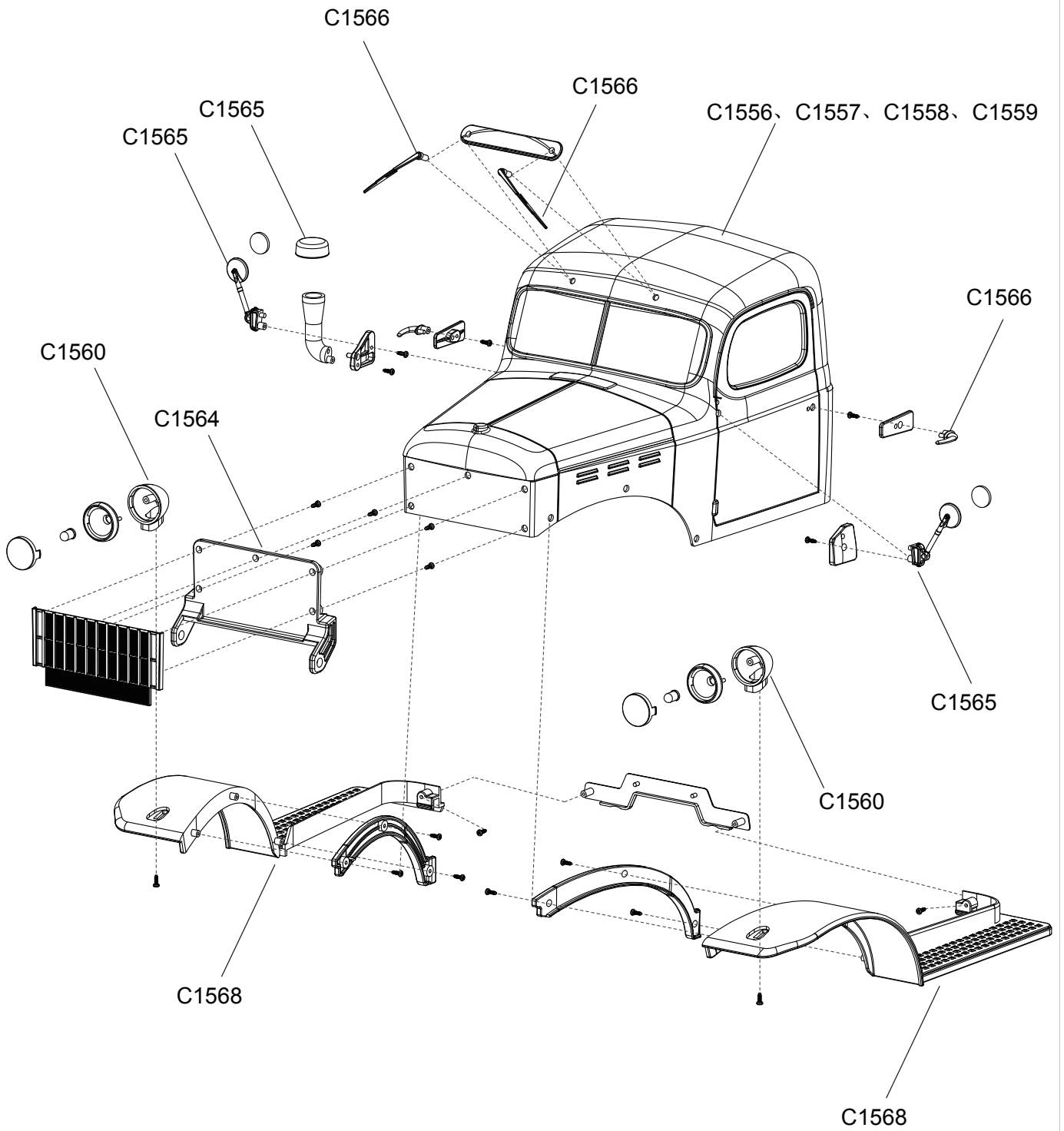

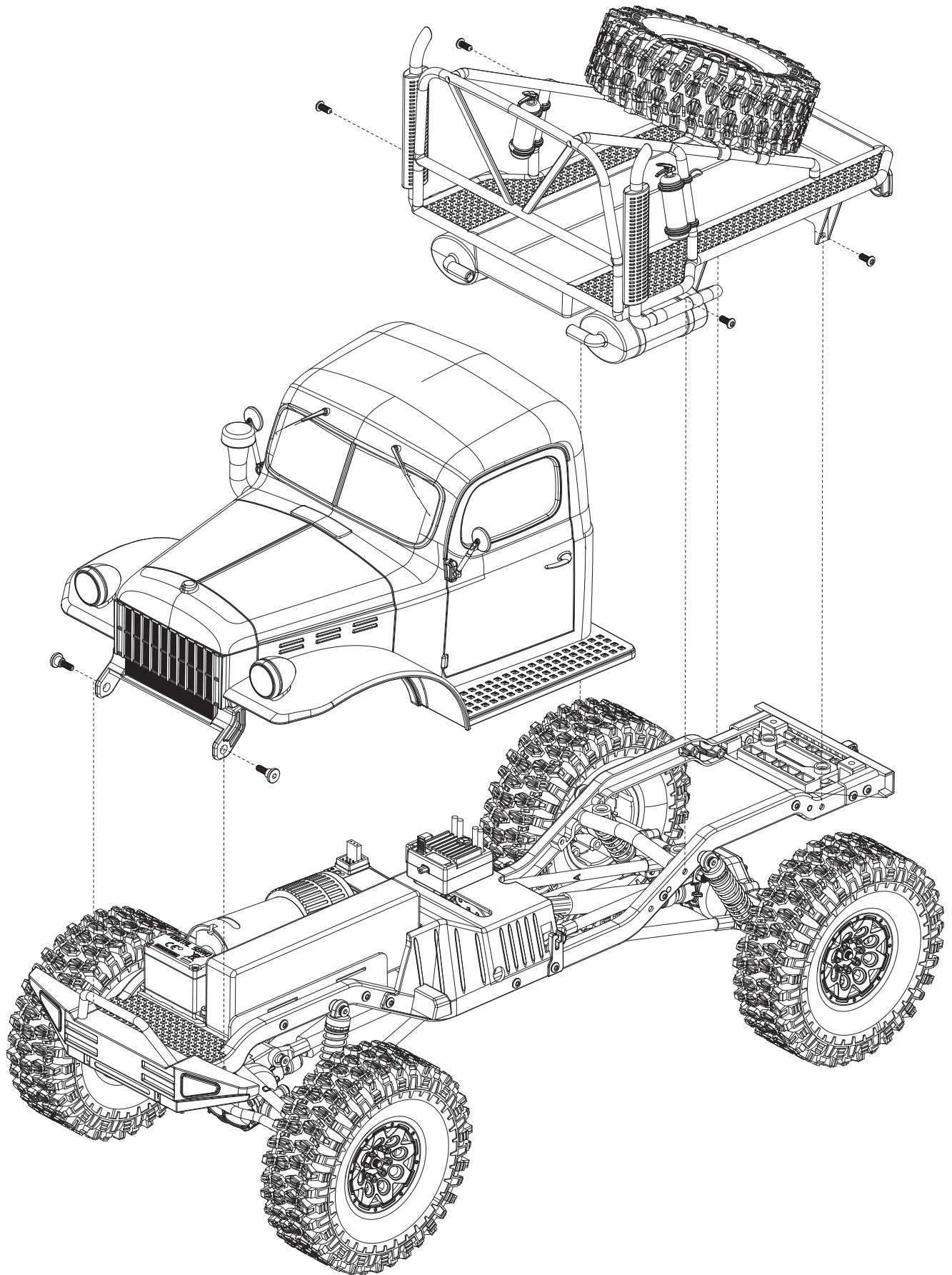



Tel:+86-0755-61811796

E-mail:info@rochobby.com

Add: Room 701, Building B, Xiangshan Bay Industrial Zone, Xiangshan Road 142, Luotian Community,
Songgang Street, Baoan District, Shenzhen

电话 : 86-0755-61811796

邮箱 : info@rochobby.com

地址及电话 : 深圳市松岗街道办罗田社区象山大道142号象山湾工业区B栋701

ROBOHOBBY

14+ CE   FC
MADE IN CHINA